

MNCHIP

Celercare M5

Automatic Chemistry Analyzer

Operator's Manual

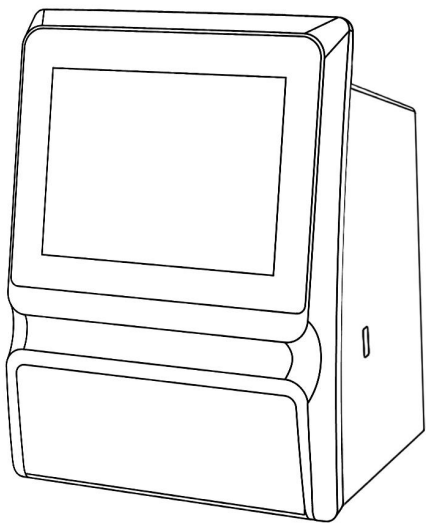

Please read the Operator's Manual carefully before use

For IVD Use Only

CE

**Tianjin MNCHIP Technologies Co., Ltd.**

Add.: 1-4F, Area, No.122 Dongting Rd, Development Zone, 300457 Tianjin P.R. China

SRN: CN-MF-000029863

Technical support Telephone: +86-131-6318-8628

Service email: service@mnchip.com

Learn more about MNCHIP, other products can log in: <http://www.mnchip.com>

**Umedwings Netherlands B.V.**

Add.: Treubstraat 1,2288EG,Rijswijk, the Netherlands

SRN: NL-AR-000000444

Email: ar@umedwings.eu

Issue Date:2026.03.12

Version: 2.5

©2022 Tianjin MNCHIP Technologies Co., Ltd.

Table of Contents

STATEMENTS	1
SAFETY PRECAUTIONS	3
SECTION 1 GENERAL INFORMATION	7
1.1 Intended Use	7
1.2 Introduction	7
1.3 Analyzer and Environmental Specification	8
1.4 Technical Support	8
1.5 Symbols Used in Labeling	9
1.6 Transport and Storage	10
SECTION 2 INSTALLATION	12
2.1 Unpacking	12
2.2 Installation	14
2.3 Setup	14
SECTION 3 SAMPLE ANALYSIS AND RESULT	17
3.1 System Description	17
3.2 Sample Requirements	17
3.3 Preparing the Reagent Disc	18
3.4 Sample Analysis	23
3.5 Canceling Analysis	28
3.6 Report	29
3.7 Recalling Results	31
SECTION 4 CALIBRATION AND QUALITY CONTROL	34
4.1 Calibration	34
4.2 Quality Control	34
4.3 Control Analysis	36
SECTION 5 CONFIGURING THE ANALYZER	42
5.1 Analyzer Information	42
5.2 Changing Date and Time	43
5.3 Network Connection	44
5.4 Setting Sound	45
5.5 Setting Language	46
5.6 Baud Rate	46
5.7 Report Layout	47
5.8 Sample Type	50
5.9 Permission Management	52
5.10 Setting LIS Function	56
5.11 Operation Settings	58

5.12 Backup58
 5.13 Other Settings59

SECTION 6 TROUBLESHOOTING 60

6.1 Electrostatic Discharge 60
 6.2 Error Codes for Analyzer and Troubleshooting 60
 6.3 Common Error Codes for Reagent Disc and Troubleshooting 61

SECTION 7 MAINTENANCE 62

7.1 Cleaning the Analyzer62
 7.2 Cleaning the Air Filter 62
 7.3 Updating the Analyzer Software63
 7.4 Software Recovery68
 7.5 Installing Thermal Printer Paper71

SECTION 8 MNCHIP MEDICAL DATA MANAGEMENT PLATFORM..... 73

8.1 MMDMP 73
 8.2 Installing the MMDMP73
 8.3 Login 75
 8.4 ‘Main Screen’ Description 76
 8.5 Settings 78
 8.6 Capture Results using MMDMP 83
 8.7 Report Printing 85
 8.8 Troubleshooting 86

Statements

Thank you for purchasing the Celercare M5 Chemistry Analyzer. This manual is intended for operators who have completed the training course offered by MNCHIP, or MNCHIP's authorized dealers. Please read and understand the Operator's Manual carefully before operating the system.

Celercare M5 Chemistry Analyzer is IVD medical equipment. It can be used in medical testing institutions. Symbols Used in Labelling complies with ISO 18113-3.

MNCHIP warrants to the original equipment purchaser of this product, the equipment will be free from defects or deficiency in design, material, and workmanship for a period set forth below, provided that the customer has completed and fed back the Product Registration Card.

To obtain service under warranty, contact the Distributor from which you originally purchased this product. If the performance issue is not handled to your satisfaction, please contact MNCHIP Customer Service. If you have a specific contract with MNCHIP, contact MNCHIP Customer Service directly.

MNCHIP's obligation under this statement is limited to repairing or replacing, at MNCHIP's option, any parts returned by the purchaser.

MNCHIP will not be responsible for any incidental, special, or consequential losses, damages, or expense directly or indirectly arising from the use of this product.

The warranty shall become null and void for any equipment that:

1. has been subjected to misuse, negligence, abuse, accident, or force majeure;
2. has been impaired by modification or repaired by anyone other than an MNCHIP Service Representative or an authorized MNCHIP representative;
3. has had the original MNCHIP serial number label or product identification markings altered or removed;

4. has had any non-standard accessory attachments affixed, or modifications made.

Thank you for purchasing MNCHIP products.

Safety Precautions

This product conforms to Regulation (EU) 2017/746, Class A. CE

To use the analyzer safely and effectively, please observe the following precautions. If the system is used in a manner not specified by the manufacturer, the protection provided by the analyzer may be impaired.

Safety information and note

Celercare M5 Chemistry Analyzer has a built-in centrifuge which complies with EN/IEC 61010 2-020.

Because the centrifuge module is built into the equipment, the operator is prohibited to replace the centrifuge, rotor and related accessories.

Centrifuge installation, operation, maintenance without special requirements and instructions, according to the corresponding requirements of the Chemistry Analyzer.

According to the biochemical analyzer program, the centrifuge speed can be controlled up to 5500rpm, only centrifuge our biochemical reagent chip.

Celercare M5 Chemistry Analyzer has been verified by transportation tests and complies with ASTM D4169:2016 DC13.

If the analyzer is not used in the manner prescribed by the manufacturer, it may compromise the protection provided by the analyzer.

Wi-Fi

Celercare M5 Chemistry Analyzer complies with EN 300 328 V2.2.2:2019, EN 62311:2008. EN 301 489-1 V2.2.3:2019, and EN 301 489-17 V3.2.4:2020.

EMC information and note

This product complies with the emission and immunity requirements of EN/IEC

61326-2-6 and EN/IEC 61326-1.

This equipment has been designed and tested to CISPR 11 Class A. In a testing environment it may cause radio interference, in which case, you may need to take measures to mitigate the interference.

It is the manufacturer's responsibility to provide equipment electromagnetic compatibility information to the customer or user.

It is the user's responsibility to ensure that a compatible electromagnetic environment for the equipment can be maintained in order that the device will perform as intended.

Before using the equipment, the electromagnetic environment should be evaluated prior to operation of it.

Do not use this equipment in close proximity to sources of strong electromagnetic radiation (e.g. unshielded intentional RF sources), as these can interfere with the proper operation.

Prevention of System Failures and Flammability

The instrument must be installed correctly according to the installation environment and the installation conditions shown in this manual.

Preventing Electric Shocks

Never remove the covers secured by screws, such as the rear cover and side covers, unless being guided by the authorized personnel of MNCHIP. If liquid spills or leaks occur inside the system, please contact your service provider or MNCHIP Technical Support. Careless operation with liquid present may result in an electric shock.

Preventing Infection

If samples used with the system are mishandled, there is a risk of being infected. Do not touch the samples with bare hands. Be sure to wear gloves to protect yourself from infection. Should any samples come into contact with your skin, thoroughly

wash the area that comes into contact with the sample and consult a physician. Immediately wipe off any contaminants from the system. For details, please check OSHA guidelines in your country. You may also refer to:

Laboratory Biosafety Manual (4th Edition) WHO (2020).

Directive 2000/54/EC of the European Parliament and of the Council of 18 September 2000 on the protection of workers from risks related to exposure to biological agents at work (seventh individual directive within the meaning of Article 16(1) of Directive 89/391/EEC)

OSHA 29 CFR Part 1910 ('Occupational Safety and Health Standards'), Standard Number 1910.1030 ('Toxic and Hazardous Substances: Blood borne Pathogens'), which can be found on the Internet by going to <http://www.osha.gov> (United States Department of Labor) and searching for '1910.1030'.

WARNING: Operators must also be aware of state and local OSHA biohazard regulations that may specify requirements in addition to the federal regulations and must also ensure compliance procedures are in place.

Handling Reagents

Reagent beads may contain acids or caustic substances. The operator does not come into contact with the reagent beads when following the recommended procedures. In the event that the beads are handled (for example, cleaning up after dropping and cracking a reagent disc), avoid ingestion, skin contact, or inhalation of the reagent beads.

Treating Waste

Used reagent discs contain human blood samples. Follow good laboratory safety practices when handling and disposing of used discs. For proper waste disposal methods, refer to your local government guidelines. For proper handling of substances with a biosafety level 2, refer to your Centres for Disease Control/National Institutes of Health manual. You may also refer to:

Directive(EU)2018/851 of the European Parliament and of the Council of 30 May

2018 on waste and repealing certain Directives.

The CLSI document GP05 'Clinical and Laboratory Standards' guideline can be found on the Internet at <http://www.clsi.org>.

WEEE Compliance

Celercare M5 Chemistry Analyzer complies with Directive 2012/19/EU of the European Parliament and of the Council of 4 July 2012 on waste electrical and electronic equipment (WEEE).



Compliance is indicated on the Chemistry Analyzer hardware using the Wheelie Bin symbol.

Customers should contact their distributor or MNCHIP, the manufacturer, to arrange for disposal of their equipment electrical and electronic hardware at the end of the product life.

RoHS Compliance

Split the instrument and determine the Pb, Cd, Hg, Cr(VI), PBBs, PBDEs, DEHP, BBP, DBP, and DIBP content in the parts. the Celercare M5 Chemistry Analyzer complies with RoHS Directive 2011/65/EU (RoHS 2.0) and its subsequent amendments, Directive(EU)2015/863.

Section 1 General Information

1.1 Intended Use

The Celercare M5 Chemical Analyzer provides quantitative in vitro determinations of clinical chemical analytes in lithium-heparinized whole blood, heparinized plasma, or serum.

It is intended to be used in a clinical laboratory setting or point-of-care location.

1.2 Introduction

The MNCHIP Celercare M5 analyzer is based on microfluidics technologies. The analysis system consists of a small analysis device and a disposable reagent disc with integrated reagents. The analyzer contains the following components and features:

- Color LCD screen for human-computer interaction
- A variable speed motor for rotating the reagent disc to drive the sample flow
- A photometer to measure analyte concentrations
- Main control circuit board control testing and analytical functions
- Built-in wireless communication module for convenient software upgrades and remote technical support
- A QR code scanner on the side of the analyzer is used to scan the information required for testing on the reagent disc and can also be used to scan patient information
- A built-in thermal printer to prints patient and control results

The reagent disc contains a dilution box in the middle (some types do not, depending on the disc type) and dry reagent beads in cuvettes on the edge. All blood separation and sample diluent mixing is performed within the disc itself.

To perform an analysis, the operator collects a blood sample (lithium heparinized whole blood or plasma, serum), pipettes the sample (some disc types also need diluent) in the reagent disc, insert the disc in the analyzer drawer at the front of the analyzer and enter the patient information. When the analysis is complete, the results can be read on the touch screen or printed via the built-in printer. An Ethernet port, a

USB port and wireless network are available so that data can be sent to an external printer, computer, memory stick, data cloud or laboratory information systems / electronic patient record systems (LIS / EMR).

Depending on the sample type and reagent combination, the detection time is about 7-12 minutes

Note: This manual includes analyzer and screenshots. These screenshots are for reference only. All screens represent typical use and installation, although it may be different from the screen on your system.

1.3 Analyzer and Environmental Specification



















Item	Description
Analyzer Dimensions	260mm(L)×230mm(W)×325mm(H)
Weight	Ca. 5.5kg
Mode of Operation	Continuous
Ambient Operating Temperature	10~30°C(50– 86°F),indoor use
Atmospheric Pressure	86.0 kPa~106.0 kPa/2000 m (6562 ft)
Humidity	40%~85%
Power Requirements	120 VA
Main Supply Voltage	100-240 volts AC, 50-60 Hz
Light Source	Xenon lamp
Reaction Volume	100μL

1.4 Technical Support

MNCHIP Technical Support teams are trained to answer questions regarding the operation of the chemistry analyzer. Please contact: **E-Mail:** service@mnchip.com

1.5 Symbols Used in Labeling

The following symbols are found on the analyzer or labelling:

Item	Description
	Biological risks
	USB connection
	CE MARK
	Serial number
	Direct current
	Date of manufacture
	Manufacturer
	Catalogue Number
	Authorized representative in the European Community
	Unique device identifier
	In vitro diagnostic medical device
	Please refer to the user manual or electronic user manual
	Caution. Refer to any accompanying documents
	Electrical and electronic equipment, do not discard at will, please recycle
	Fragile, handle with care
	Keep dry
	This is the correct upright position of the distribution packages for transport and/or storage
	Distribution packages shall not be rolled or turned over



Up to 6 identical transport packages can be stacked on the bottom package

1.6 Transport and Storage

1.6.1 Transport

Celercare M5 Chemistry Analyzer has been tested and found to comply with the ASTM D4169:2016 DC13.

During transportation of the products, they shall be kept in good condition with a canvas covering if necessary to prevent dampness and rain damage in the transportation process.

The transport vehicle of any other party/courier shall be orderly, compact, reasonable, safe and reliable to prevent damage of the goods caused by shaking in the process of transportation.

In the process of transportation, do not transport with inflammable, explosive and corrodible articles in the same vehicle and the product components should not come into contact with or be subjected to rain, snow or liquid substances leaching or mechanical damage.

1.6.2 Storage

Storage environment temperature: 0°C~+40°C.

Storage environment humidity: not more than 85%.

Products should be stored in the original packaging box, maintain the original protective packaging.

The warehouse where the products are stored shall be protected against moisture, dust, shock and corrosion. It is recommended to install air conditioning, lighting equipment and other equipment in the warehouse.

Section 2 Installation

The analyzers are strictly inspected by our professional staff before packaging and transportation, and through the designated transportation company to transport the product to the installation site. After receiving the analyzer, please carefully check whether the following damage exists in the outer package before unpacking:

- Apparent deformation
- Marks of immersion
- The marks of the impact
- Signs of being opened

In case of any damage, please do not open the product, and immediately inform our after-sales service personnel or local dealers.

If no damage is found, you can perform the following steps to install the device.

2.1 Unpacking

2.1.1 Take the Celercare M5 Chemistry Analyzer out of the shipping carton. Place the analyzer on a level surface that is free of hair, dust, and other contaminants. Do not place the analyzer in direct sunlight or any other heat source.

2.1.2 The following figures show the analyzer's functional description of each part.

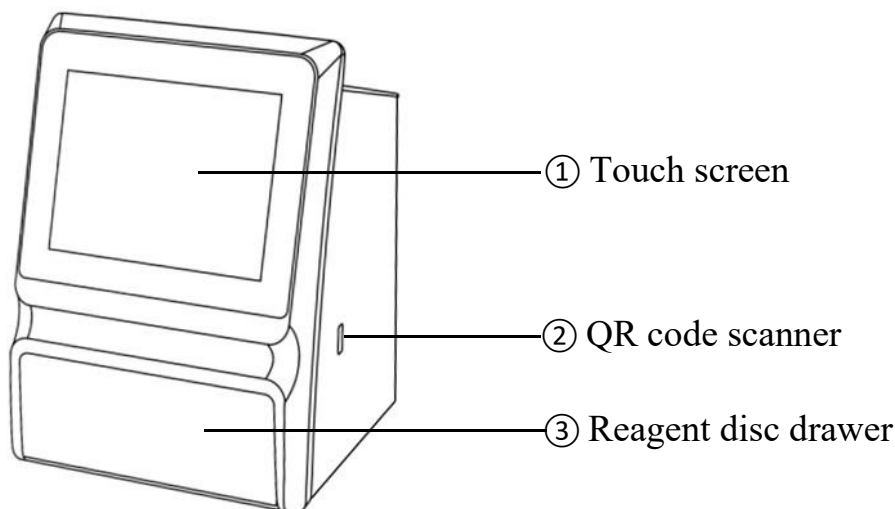

The front of the analyzer

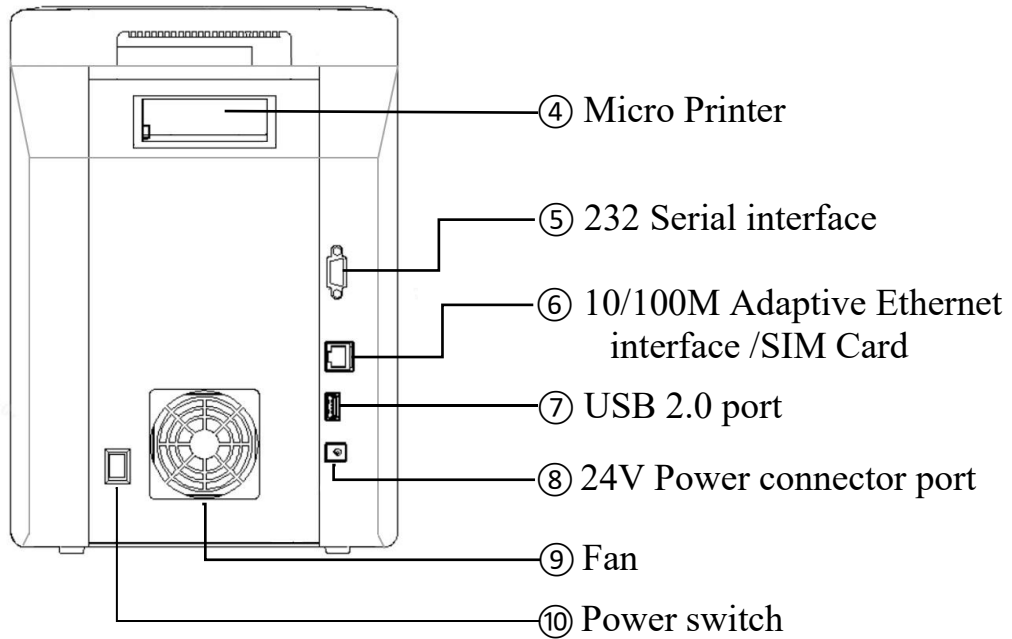

The rear of the analyzer

NO.	Item	Function
1	Touch screen	For human-computer interaction
2	QR code scanner	Scan the QR code of the reagent
3	Reagent disc drawer	Test area, place reagent disc
4	Micro Printer	Print patient and control results
5	232 Serial interface	Data transfer, computer connection
6	10/100M Adaptive Ethernet interface /SIM Card	Access the network by connecting network cables
7	USB 2.0 port	External printer connection, external scanner connection
8	24V Power connector port	Power connector port
9	Fan	Ventilation and heat dissipation during operation
10	Power switch	Turn on/Turn off the device

2.1.3 Check the components received with the Celercare M5 Chemistry Analyzer against the Packing List to make sure everything required to set up the analyzer is included.

2.2 Installation

2.2.1 Set up the analyzer on a surface as follows:

- On a level surface with nothing blocking the reagent disc drawer.
- Free of vibration and sudden jolts.
- Free of hair, dust and other contaminants.
- Located in an ambient operating temperature of 10–30 °C (50–86°F).
- Away from direct sunlight and all other potential heat sources.
- At least 30 cm (12 inches) away from any wall to provide adequate ventilation and access to the power connection and USB ports.

2.2.2 Plug the power cable into the analyzer. Then, plug the detachable power supply cord into the power adapter and into a grounded electrical outlet.

Caution: DO NOT use improperly rated power cords or power adapters. To prevent power surges or drain, DO NOT plug the analyzer into the same circuit as a centrifuge or any other high-current device. MNCHIP also recommends using a surge protector of the same type used for computers.

Please complete the warranty card after the installation and send the scanned warranty card via email to service@mnchip.com within 10 days to start the warranty period. Customers are placed on the customer mailing list to receive any information pertaining to the analyzer and ancillary products, such as software upgrades.

2.3 Setup

- a. Press the Power switch to turn on the analyzer. During the self-testing and the warming period, the display will show the following image.

Note: The analyzer may require additional time for the heaters to warm the analyzer to operating temperature under low ambient temperature.



- b. After passing the self-testing and reaching operating temperature, the analyzer is ready to run the first reagent disc, as shown in the image below.

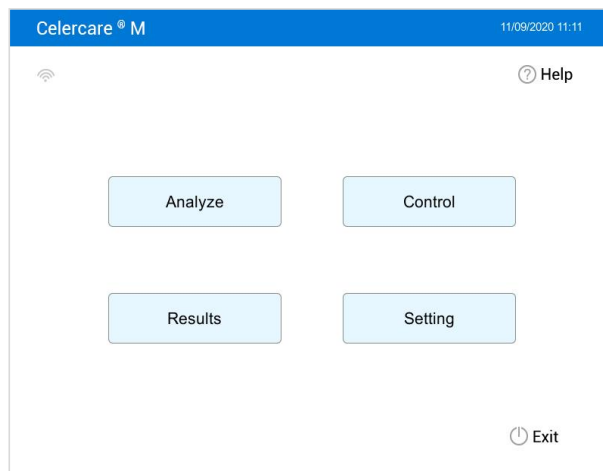

- c. Check the analyzer date and time to ensure they are correct. Refer to **Section 5.2, ‘Changing Date and Time’** for directions.
- d. Shutdown the analyzer by pressing  **Exit** on the Main screen, then turn off the power switch.

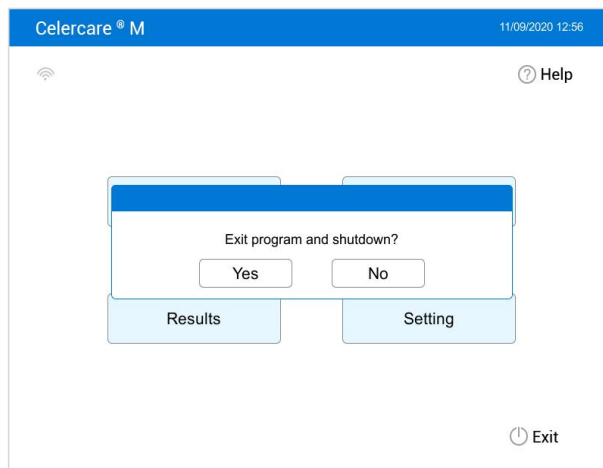

- e. The analyzer's built-in thermal printer prints patient and control results.
- f. Reference ranges are preset in the analyzer. The range values can be changed using the Customizing Reference Range feature described in **Section 5.7**.

Section 3 Sample Analysis and Result

3.1 System Description

1. The Celercare chemistry system consists of a portable analyzer and disposable single-use reagent discs. Each reagent disc contains all the reagents needed to perform a panel of tests on a single sample. Be sure to become familiar with the system before running samples.
2. The Celercare analyzer uses centrifugal and capillary forces to process heparinized whole blood samples and distribute diluted plasma to the reaction chambers (cuvettes) in the reagent disc. Serum and heparinized plasma samples are processed in a similar manner. The analyzer optically measures the chemical reactions and calculates analyte concentrations from these measurements and from encoded calibration data contained on the QR code on the reagent disc pouch.
3. Results are stored in memory and can be printed the built-in thermal printer or downloaded to an external personal computer for MNCHIP Medical Data Management Platform (MMDMP).The touch screen display provides easy communication with the analyzer. The touchscreen shows procedural instructions, indicates the status of the analyzer and presents any error messages. For error messages details, see **Section 6**.

3.2 Sample Requirements

3.2.1 Sample Requirements

1. The CelercareM5 Chemistry Analyzer only accepts lithium-heparinized whole blood, plasma or serum samples.

Note: When collecting the sample in lithium heparin collection tubes, fill the tube at least half-way so the anticoagulant does not become too concentrated in the sample.
2. For the sample type applicable to each disc, please refer to the corresponding kit IFU.

3. A sample size of 90-120 μl is required.
4. Whole blood must be analyzed within 60 minutes of collection, or separated into plasma or serum.

Note: If not analyzed immediately, plasma or serum can be stored at room temperature for no longer than 5 hours after centrifugation. If storage for more than 5 hours is required, refrigerate the sample in a capped tube at 2-8 °C (36-46 °F) for no longer than 48 hours or store it at -10°C for up to 5 weeks in a freezer with no self-defrost cycle. Under these conditions, there will be no clinically important changes in most analyte concentrations.

Caution: To prevent hemolysis, do not refrigerate or shake whole blood.

5. For accurate interpretation of glucose results, the patient should fast for at least 12 hours before the sample is collected.

3.2.2 Test Tube Order (ISO 6710:2017).

To prevent contamination, always fill test tubes in this order:

- Sodium citrate. Used for coagulation determinations.
- SST tube with clot activator.
- Serum only, no anticoagulant.
- Lithium heparin. Anticoagulant for chemistry only.
- EDTA. Anticoagulant for hematology only.

Caution: Do not remove a sample from the disc and try to reintroduce it to the disc. Never place lithium heparin tubes in a test-tube rocker.

EDTA contamination severely affects results, especially Ca and K⁺.

Use of a sodium heparin tube will falsely elevate Na⁺ results.

3.3 Preparing the Reagent Disc

3.3.1 Disc Structure and Function

A total of 29 cuvettes are located around the periphery and some of the cuvettes contain test-specific lyophilized reagent beads needed to perform one or more tests on a single sample.

- A specially designed cuvette detects whether sample volume was

sufficient.

- A specially designed cuvette detects whether diluent volume was sufficient.
- A cuvette verifies that sufficient diluted sample was delivered to the reaction cuvettes an empty cuvette captures excess fluids
- 21 cuvettes contain test-specific lyophilized reagent beads
- The sample port, marked by red to a molded circle on the disc's upper surface, provides access to the sample chamber.
- Type A disc: The diluent port, marked by white to a molded circle on the disc's upper surface, provides access to the diluent chamber.
- Type B disc: A sample diluent is sealed in a container inside the disc. At the beginning of the reaction cycle, open this container and releases the diluent.
- The structure of the reagent discs are as shown below:

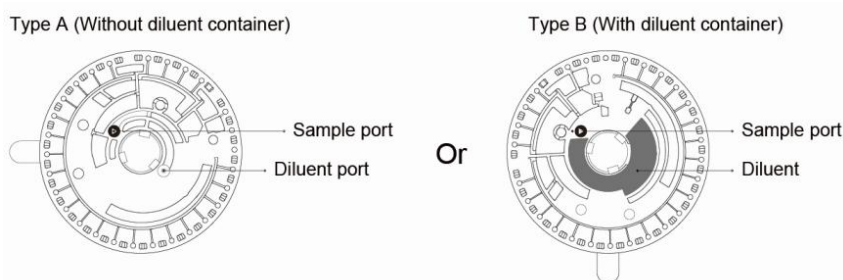

The analyzer separates a lithium-heparinized whole blood sample by centrifugation inside the disc. Plasma and serum samples are unaffected. Precisely measured quantities of sample and diluent are delivered to the mixing chamber. Centrifugal and capillary forces then deliver the diluted sample to the cuvettes, where it dissolves the reagent beads and initiates the chemical reactions. The reaction products in the cuvettes are then measured photometrically.

3.3.2 Preparing the Reagent Disc

Open the disc pouch at the notch on the top right edge of the package. Take the reagent disc out and put on the table in a flat position.

A. For Type A disc (Without diluent container):

- a. Dispense sample: Use the 100 μL volume pipette. Place a clean pipette tip on the end of the pipette.

Holding the pipette with four fingers, press the top button of the pipette with your thumb to the stop position and hold.

Immerse the pipette tip below the sample level and slowly release the button to draw up the sample. Remove the pipette from the sample. Make sure there are no air bubbles in the tip.

Note: Whole blood samples obtained by venipuncture must be homogeneous before transferring a sample to the reagent disc. Gently invert the collection tube several times just prior to sample transfer. Do not shake the collection tube; shaking may cause hemolysis.

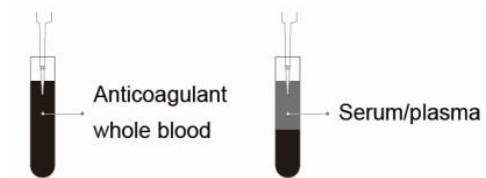

- b. Adding sample: Ensure the pipette tip is vertically inserted into the sample well in the disc, then tilt 45° . Press the top button slowly until all the sample is dispensed into the disc.

After adding the sample, discard the tip into a biohazard container.

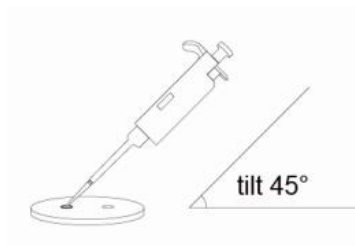

Caution: Ensure the whole blood sample is gently inverted before pipetting. Do not violently shake to avoid haemolysis.

- c. Adding diluent: Use the 430 μL volume pipette to dispense approximately 430 μL of sterile water for injection (SWI) into the diluent chamber via the diluent port with the same procedure used to fill the sample chamber.



Caution: *Keep straight when adding diluent. Do not use saline, mineral water or tap water.*

B. For Type B disc (With diluent container):

- a. Opening the diluent container: With the aluminum strip on the reagent disc facing towards you. Pull the aluminum strip off the reagent disc in the extended direction of the aluminum strip to open the diluent container, then the diluent is released into the diluent chamber of the reagent disc.

Then place the reagent face up on the flat surface.

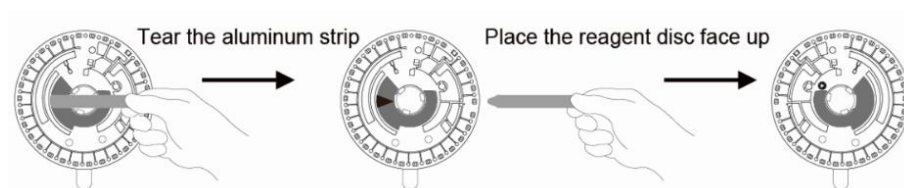

- b. Dispense sample: Use the 100 μL volume pipette. Place a clean pipette tip on the end of the pipette.

Holding the pipette with four fingers, press the top button of the pipette with your thumb to the stop position and hold.

Immerse the pipette tip below the sample level and slowly release the button to draw up the sample. Remove the pipette from the sample. Make sure there are no air bubbles in the tip.

Note: *Whole blood samples obtained by venipuncture must be homogeneous before transferring a sample to the reagent disc. Gently invert the collection tube several times just prior to sample transfer. Do not shake the collection tube; shaking may cause hemolysis.*

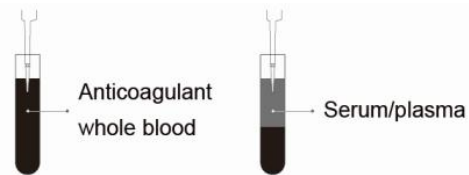

- c. Adding sample: Ensure the pipette tip is vertically inserted into the sample well in the disc, then tilt 45°. Press the top button slowly until all the sample is dispensed into the disc.

After adding the sample, discard the tip into a biohazard container.

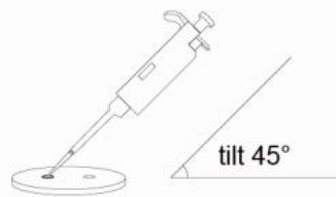

Caution: Ensure the whole blood sample is gently inverted before pipetting. Do not violently shake to avoid haemolysis.

Note: Disc Storage and Handling

- Store each reagent disc as described on its label. This keeps the disc's reagents stable until the expiration date printed on the disc's foil pouch. The analyzer automatically rejects any expired disc.
- Discs can be used directly from the refrigerator (stored at 2-8 °C) without warming.
- Do not expose discs -in or out of their foil pouches - to direct sunlight or to temperatures above 32 °C (90 °F).
- Inspect the unopened foil pouch for tears and punctures. A torn or damaged pouch can allow moisture to reach the disc and reduce reagent performance.
- Once the pouch is opened, discs must be used within 20 minutes. Do not place the disc back in the refrigerator for later use.
- Keep discs clean. Handle them only by their edges to avoid smudges on the optical surfaces. Use a lint-free tissue to remove any spilled blood from disc surfaces.
- Wear powder - free gloves while handling reagent discs or operating the analyzer. Powder can disrupt the analyzer's optical components.
- Hold reagent discs flat after introducing the sample or control to avoid spillage.
- Discs are fragile - always handle with care. Inspect every reagent disc for damage before use. Never use a damaged disc.

3.4 Sample Analysis

This section includes detailed, step-by-step instructions for performing analysis using the analyzer.

- a. After passing the self-testing, the analyzer will display the Main screen (operating interface) as the following image shows.

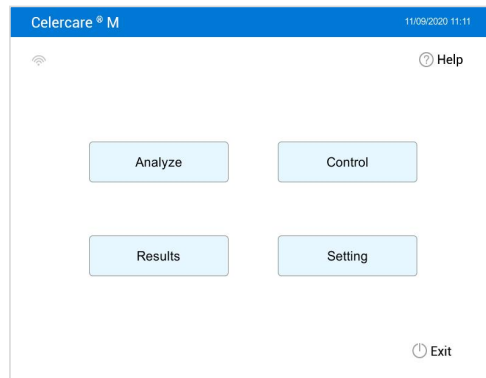

- b. Press '**Analyze**', then the screen for selecting the sample type is displayed. Select '**Whole Blood**', '**Serum**' or '**Plasma**', the screen for scanning the QR code is then displayed.

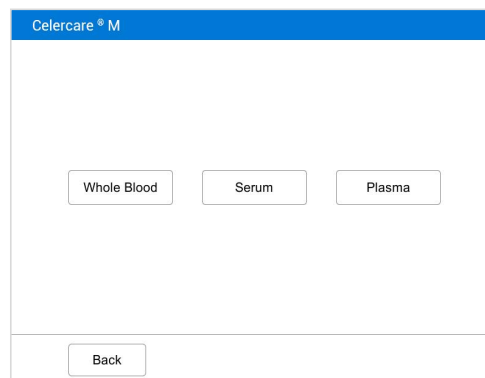

- c. Scan the QR code on the label of the foil pouch. The QR code contains the disc information e.g. disc identification code, lot number, expiration date and calibration data etc.

Note: Please determine before scanning that the QR code label is flat and the light in the surrounding environment is sufficient.

- Place the QR code in front of the QR scanner on the right side of the analyzer. Hold still to scan the QR code.

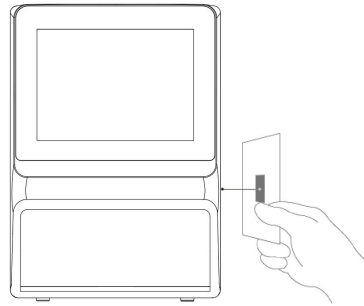

- Once the scan is complete, a prompt with the disc type name will display on the screen. (If the disc is found to be expired, a prompt appears. Rescan a new disc.)

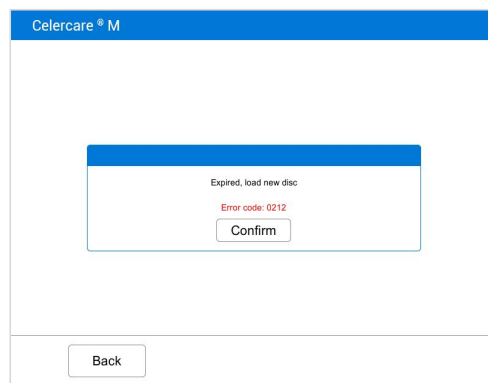

- Press 'Yes' to confirm it is the right disc type to run the patient sample.

OR

Press 'No' to cancel the disc information and scan a new disc.

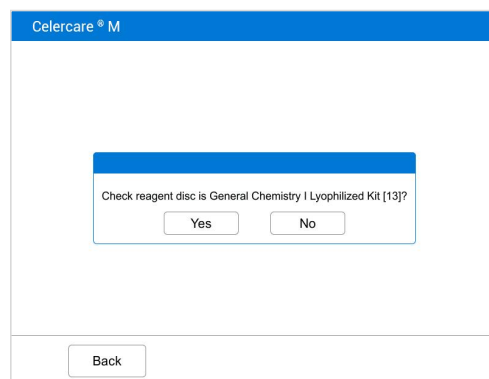

- d. Select the patient's gender. Then, the disc drawer will open.

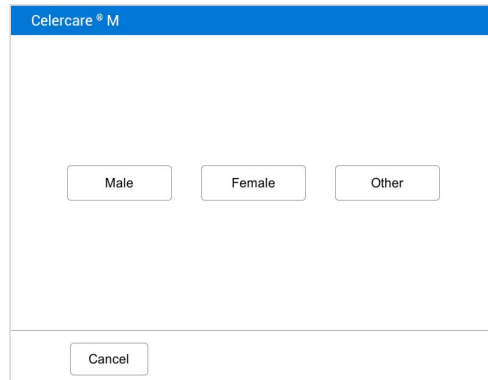

- e. According to the procedure in **Section 3.3**, place the disc in the recessed area of the drawer (if there is a blue film on the surface of the disc, please remove it first), then press ‘Close’.

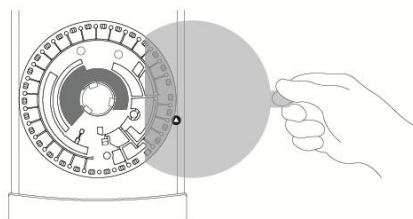
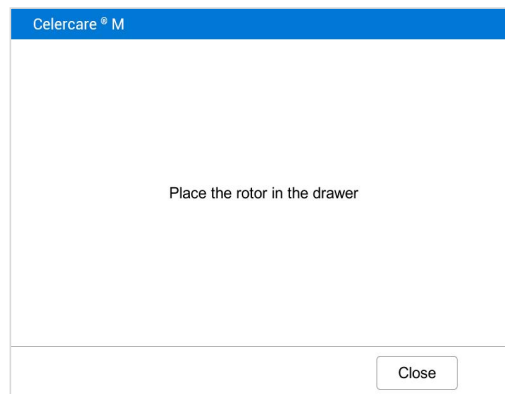

- f. Press ‘Yes’ to confirm the blue film has been removed and the disc drawer will close.

Celercare® M

Has the blue film been removed from the disc?

Yes No

Note: If it is a new version disc, there is no blue protection film, run the test directly after adding the sample into the black round port.

- g. Use the keyboard to input the patient’s name, age and ID. Then, press ‘Next’, select the hospital department and patient area.

Celercare® M

Name:

*Age: Year

ID:

*Gender:

Department:

Patient Area:

All fields marked with * are required and must be filled

Cancel Next

The screen for selecting the department of hospital and patient area is showed as follow:



Celercare® M

Internal Medicine Surgery Pediatrics

Gynecology Obstetrics Neurosurgery

Orthopedic General surgery Oncological surgery

Cancel Back

Press ‘ / ’, to select the patient’s department. Then, selecting the patient area.

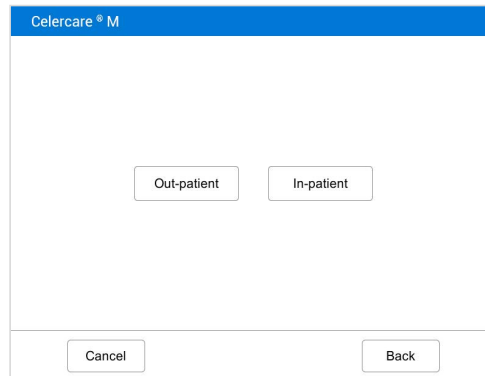

- h. After inputting the patient’s information, press ‘**Next**’, the analyzer shows the progress bar with a countdown clock.

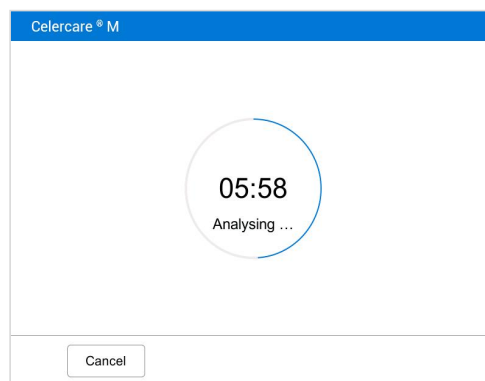

- i. After the analysis is complete, the analyzer stores the results into the database and displays the results on the screen as shown. By default, the analyzer automatically prints the results of the analysis by the analyzer’s built-in thermal printer or external printer. If the results do not print automatically, they can be recalled from the database and printed — see ‘**Recalling Results**’ in the **section 3.7**.
- j. Press ‘**Open**’ to open the drawer and remove the disc from the drawer. Then,

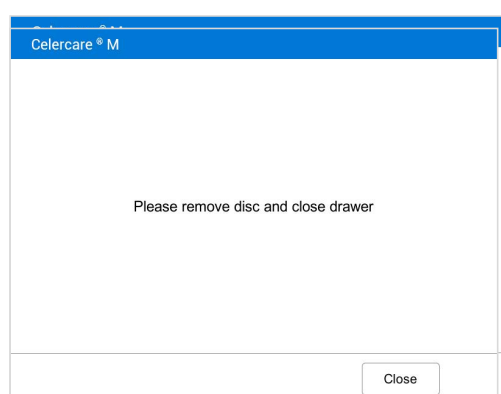

press ‘Close’ to close the drawer and return to the Main screen. The analyzer is now ready to perform another analysis.

3.5 Canceling Analysis

- a. Occasionally the analysis has to be cancelled. Press ‘Cancel’ on the screen. The display will ask for confirmation to cancel the analysis.

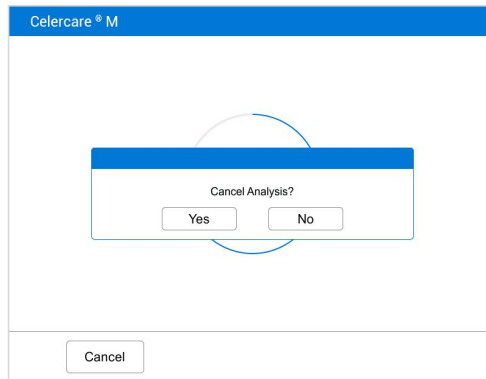

- b. After pressing ‘Yes’ to confirm, the analysis will be cancelled and the drawer will open automatically.

Note: Sometimes the analyzer may need several minutes to open the drawer, because internal procedures need to be executed before you can cancel.

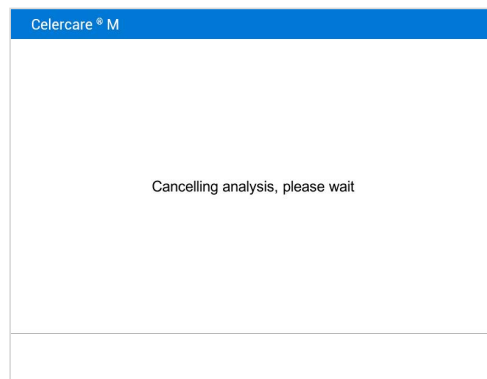

- c. Remove the disc from the drawer and press ‘Close’ to close the drawer. The analyzer is now ready to perform another analysis.

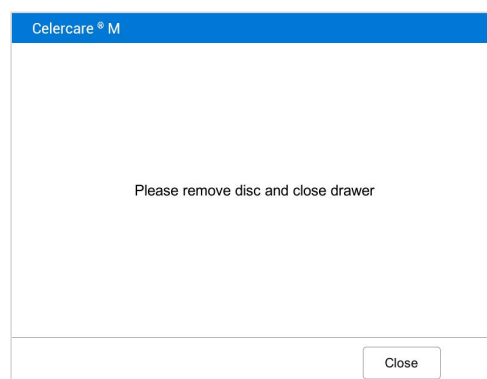

3.6 Report

A typical report printout is shown below. The heading of a typical report printout includes information such as Sample Patient Name, ID number, Gender, Age, Department, Patient Area, Sample type and Lot number. The test results section is printed in five columns: Analyte Name, Analyte Result, Indicator, Reference Range and Specified Units. The end of the report printout includes information such as the sample indices, test date and time, and blank areas for operator and reviewer to sign.

ID:31926				
Gender:Female				
Age:18 years				
Department:Pediatrics				
Patient Area:Out-patient				
Sample type:Whole Blood				
LOT:31926-20-03-180881-2				

Item Name	Result	Indicator	Ranges	Unit
K+	4.48		3.5-5.3	mmol/L
Na+	138		137-147	mmol/L
CL-	96.5	↓	99-110	mmol/L
CO2	16.6	↓	23-29	mmol/L
Ca2+	2.36		2.25-2.67	mmol/L
Mg2+	0.99	↑	0.5-0.9	mmol/L
P	1.2		0.9-1.34	mmol/L

Report DateTime:2018-9-12 09:56				
Operator:				
Reviewer:				
The results relate only to the sample tested				

Interpretation of results

- Results outside the reference range are indicated in the results by a ‘down arrow’ symbol ↓ or an ‘up arrow’ symbol ↑ printed next to the analyte concentration.
- Results outside the dynamic range are indicated in the results by a ‘less than or equal’ symbol \leq printed next to the lowest value of the dynamic range, or a ‘greater than or equal’ symbol \geq printed next to the highest value of the dynamic range.
- The Analyzer automatically calculates the concentration of low-density lipoprotein cholesterol (LDL) in each sample using the directly determined

values for total cholesterol (CHOL), high-density lipoprotein cholesterol (HDL), and triglycerides (TG). This equation (Fried Ewald equation) is not valid for triglyceride concentrations above 4.52mmol/L, non-fasting patients, and in patients with Type III hyperlipoproteinemia (dysbetalipoproteinemia). An LDL value is not reported for samples with triglycerides greater than 4.52mmol/L or if any of the directly measured analyte values is unavailable.

- The symbols ‘ – ’ are printed in place of numbers when a result is abnormal. A result may be abnormal due to reagent deterioration, interference of endogenous substances (such as hemolysis, icterus and lipemia) in the sample, interference of exogenous and therapeutic substances in the sample, sample or diluent contamination, or a concentration outside the analyzer’s capabilities. When a chemistry is suppressed --, repeat one time with a new disc. If still suppressed, please contact Technical Support.
- Samples are checked for physical interference from hemolysis, lipemia, and icterus. When some of the indices exceed the pre-established limit, the corresponding index (HEM, LIP, or ICT) is printed on the bottom of each result card to inform the operator about the interference.

Note: If the sample is identified as hemolytic, collect a new sample and run another reagent disc. If the new sample is still hemolytic, use an alternative testing method or send the sample to a reference laboratory.

Samples with hematocrit in excess of 60% packed red cell volume may appear on the result card as HEM. These samples may be spun down to get plasma then re-run in a new reagent disc.

High lipemia may be due to diet. Ensure the patient has fasted for at least 12 hours before collecting another sample. For grossly lipemia samples from fasting patients or for icteric samples, use an alternative testing method or send the sample to a reference laboratory.

- During an analysis, the analyzer checks the volumes of sample and diluent. If insufficient sample or diluent has been applied to the disc, an error report with error code 02081 or 0209/0233 is printed. Repeat one more time with a new disc loaded with sufficient sample and diluent according to the procedure in **Section 3.3**.
- In very rare instances, if sample dispensed into the sample chamber of the reagent disc may not be delivered into reaction cuvettes, or mixes improperly with the diluent, an error report with error code 0210 or 0211 is printed. The sample may be re-run using a new reagent disc. Please contact

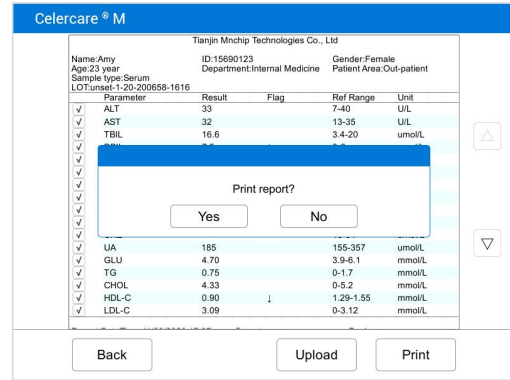
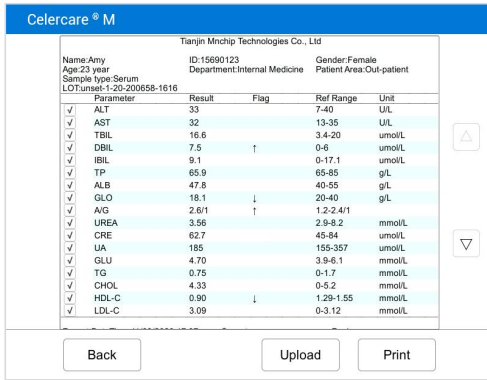

Platform.

- d. After pressing ‘Upload’, the display will show the image as follows. Select an upload path, and it will be uploaded automatically.

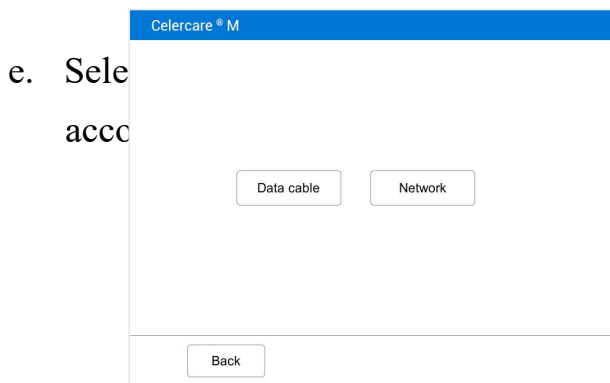

show detailed results. Press ‘Upload’
ort, press ‘Print’ to print the current

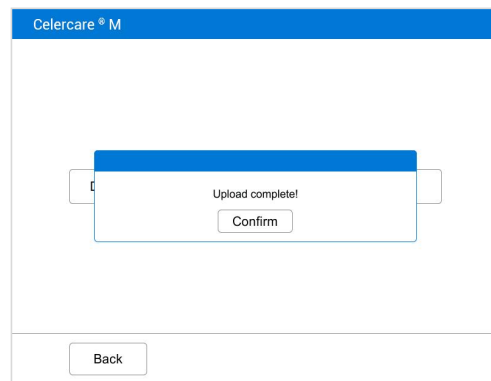

report.

The Recall function is available from the MNCHIP Medical Data Management Platform. The operator can search results by Name, Gender, Age, ID or view

patient results by date. Please refer to **Section 8**.

Section 4 Calibration and Quality Control

4.1 Calibration

Celercare M5 Chemistry Analyzer is calibrated by the manufacturer before shipment. The analyzer performs hardware self-calibration whenever the power is turned on. Each reagent bead used in the reagent disc is calibrated to a reference method and/or reference material by the manufacturer before shipment. The QR code printed on the foil pouch of the reagent disc contains the disc-specific calibration data and provides the analyzer information to calculate analyte concentrations. If the recommended procedures in the **Section Basic Operations (Section 3)** of this manual are followed, the analyte concentrations produced by the analyzer will be accurate.

4.2 Quality Control

4.2.1 Quality Control During Analysis

During analysis, the analyzer checks its components and the reagent disc to ensure accurate results.

Celercare M5 chemistry analyzer

Before analysis begins, the analyzer's photometer takes readings with the light path obstructed and also unobstructed, to determine the appropriate light intensity range, then makes sure the range is within specification. It also continually checks the performance of the motor, flash, and optics during analysis.

Reagent Disc

The analyzer checks the reagent disc during analysis to confirm the following:

- calibration factors
- expiration date
- presence of all reagent beads
- timing of fluid movement through the disc

- diluent and sample mixing
- sufficient sample in the disc
- proper dissolution of the reagent beads when mixed with sample

Each reagent disc also contains reagents to detect exposure to extreme conditions such as temperature and humidity. When the results from these reagents are within the expected range, the test results will be output normally. Otherwise, no results are printed, and run canceled appears on the display.

The analyzer also monitors reaction performance. For rate chemistries, the analyzer confirms that the reactions are linear with time and slope is within range, and monitors substrate depletion. In endpoint chemistries, the analyzer verifies the flatness (completeness) of the endpoints.

Sample

Samples are checked for physical interference. The analyzer estimates the sample indices, hemolysis, lipemia, and icterus using absorbance readings for the sample at 340 nm, 405 nm, and 467 nm, then compares them to pre-established limits for each method. When all three indices are below the method limits, the result for that method is printed on the result card. If even one index exceeds the limit, the result for the method is suppressed and the error condition displayed as HEM, LIP, or ICT.

4.2.2 Quality Control

Performance of the Analyzer or the reagent disc can be verified by running controls. A control is a biological sample or solution with a suitably contrived matrix that is analyzed for purposes of quality control. The composition of the matrix must be such that the solution closely matches that of the biological specimen for characteristics of importance to the analyzer. Control materials need to be stable and available in sufficient volumes in multiple portions and over an extended period. Many control products are available commercially. Assayed controls also come with expected values of the analytes for guidance.

For a list of approved quality control materials with acceptance ranges, please

contact MNCHIP Technical Support. Other human serum or plasma-based controls may not be compatible. Quality control materials should be stored as described in the control package insert.

For the quality control test, we strongly recommend that you follow the requirements of the local health regulatory department. In addition to this, we also recommend as follows:

- At least every 30 days
- Whenever laboratory conditions have changed significantly
- When training or retraining of personnel is indicated
- When test results do not match patient symptoms or clinical findings
- With each new lot of reagent

Samples and controls are analyzed identically by the analyzer. However, using the **Controls** option stores control results separately from patient results in the analyzer database. Control results can be printed on a report card immediately after the conclusion of the control analysis, or whenever the control results are recalled.

Handle the control as described in the control package insert. Please contact MNCHIP Technical support for assistance in interpreting control results. The analyzer automatically stores control results in a memory separate from the patient results memory. The Recall function can be used to search for specific control results without searching through all patient results stored in the memory.

Caution: Discs are fragile—always handle with care. Do not tap the disc on the workbench to empty the sample from the disc or to empty the sample from the disc. Do not use a disc that has been dropped. Inspect every reagent disc for damage before use, and never use a damaged disc.

4.3 Control Analysis

4.3.1 Control Analysis

- a. On the Main screen, press '**Control**'. Controls can be run whenever the

analyzer displays the **Main** screen.

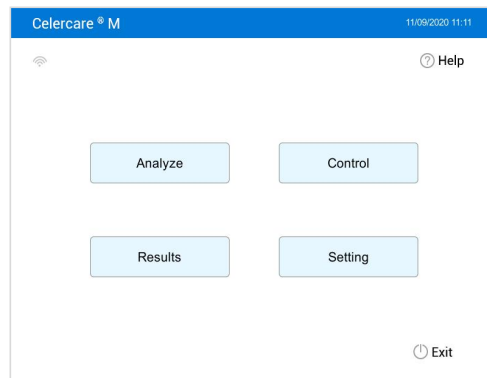

- b. Scan the QR code on the foil pouch of the reagent disc as described in **Section 3.4 Sample Analysis**.

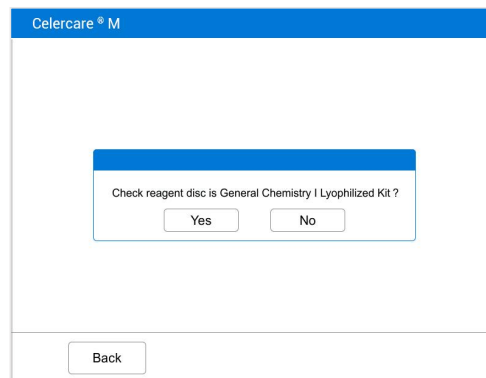

- c. Dispense the control and the diluent in the disc as described in **Section 3.3 Preparing the Reagent Disc**. Place it in the drawer of Analyzer to start

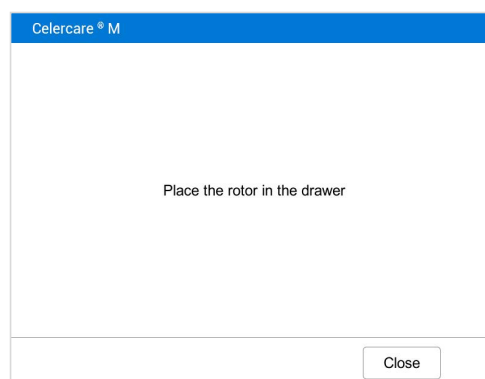

analysis.

- d. Input the control Lot number. Press 'Next' to show the progress bar with a countdown timer.

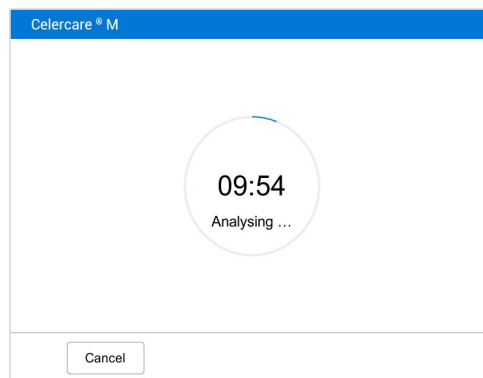
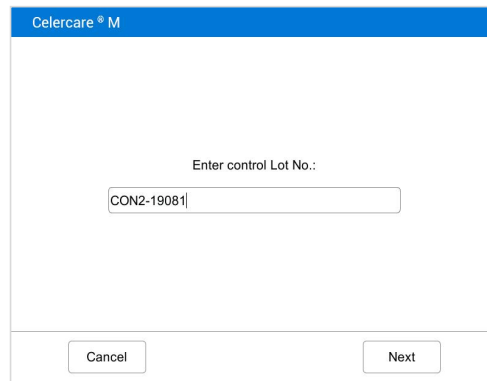

e. Countdown timer.

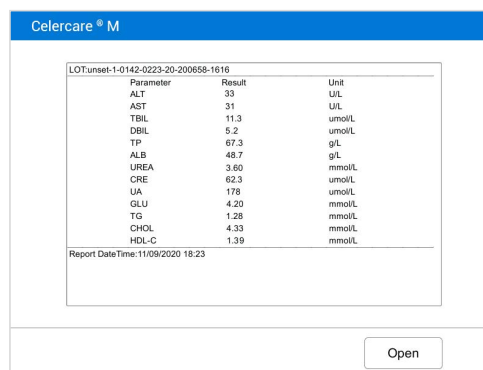

f. After the analysis is complete, the analyzer stores the results in the database. Compare the control result to the range printed on the control data sheet.

g. Press **‘Open’** to open the drawer and remove the disc. Then press **‘Close’** to close the drawer and return the analyzer to standby mode.

Note: If control results are out of range, repeat. If still out of range, please contact the Technical Support.

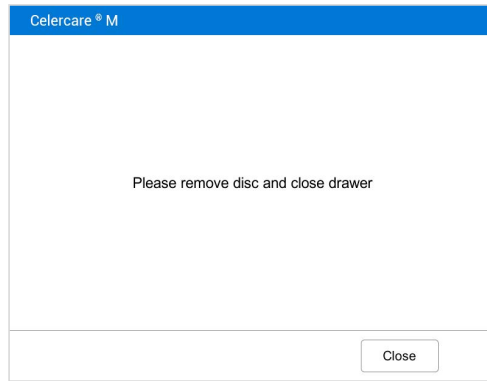

4.3.2 Recalling Control Results

- a. On the Main screen, press **'Results'**, then select **'Control'**.

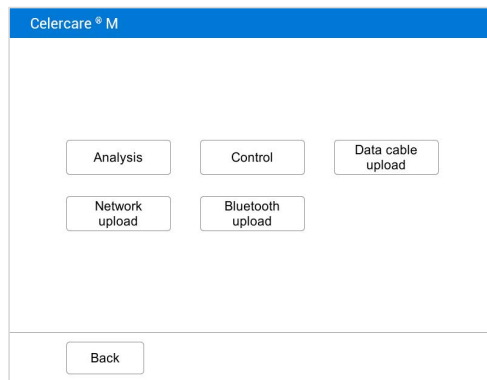

- b. Enter the date range to search control reports.

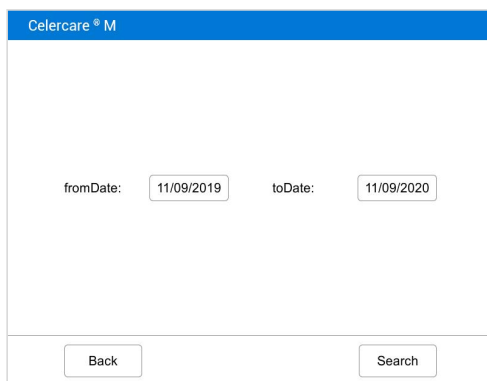

c. Select reagent disc type.

Celercare® M

Select Reagent Disc :

General Chemistry I Lyophilized Kit

Liver and Renal Function Lyophilized Kit

Back Upload

d. Select control Lot number.

Celercare® M

Select Lot No.:

CON2-19053 CON2-19081

Back

e. The detailed results of the specific control report will show. Press 'Print'.

Celercare® M

LOT:unset-1-0142-0223-20-200658-1616

Parameter	Result	Unit
ALT	33	U/L
AST	31	U/L
TBIL	11.3	umol/L
DBIL	5.2	umol/L
TP	67.3	g/L
ALB	48.7	g/L
UREA	3.60	mmol/L
CRE	62.3	umol/L
UA	178	umol/L
GLU	4.20	mmol/L
TG	1.28	mmol/L
CHOL	4.33	mmol/L
HDL-C	1.39	mmol/L

Report Date Time: 11/09/2020 18:23

Back Print

- f. The control results can be uploaded to the MNCHIP Medical Data Management Platform by pressing '**Upload**'.

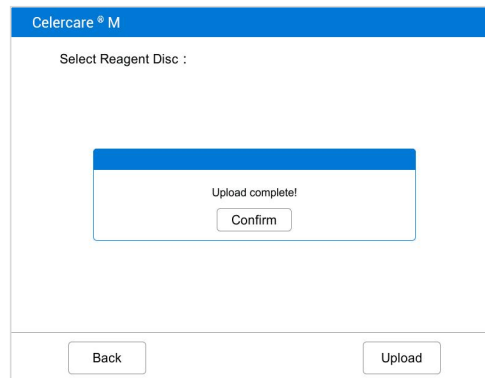

Section 5 Configuring the Analyzer

This section describes how to configure the analyzer to achieve excellent performance.

5.1 Analyzer Information

- a. On the Main screen, press ‘Setting’.

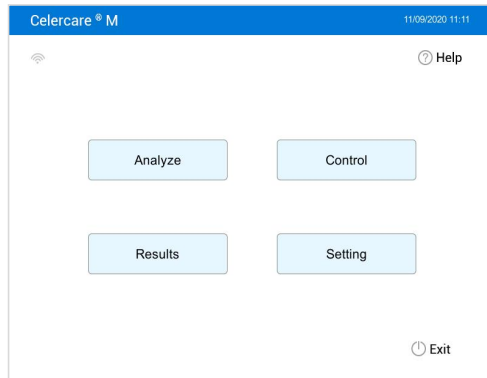

- b. Then press ‘Analyzer’.

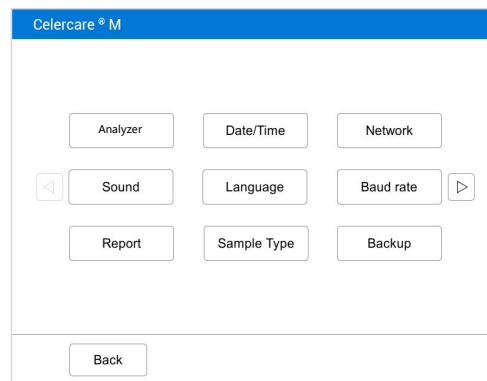

- c. The display will show the analyzer information, such as serial number, the version of the installed software and upload log. Press ‘Update’ to install the latest version. Click ‘Privacy Policy’ to read the content.

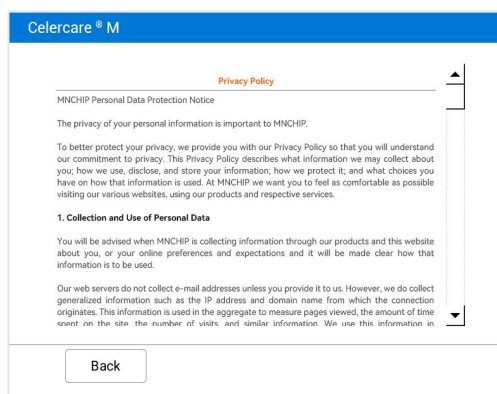
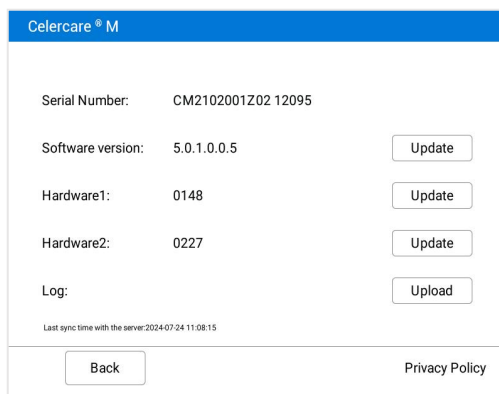

5.2 Changing Date and Time

- a. On the Main screen, press ‘**Setting**’.

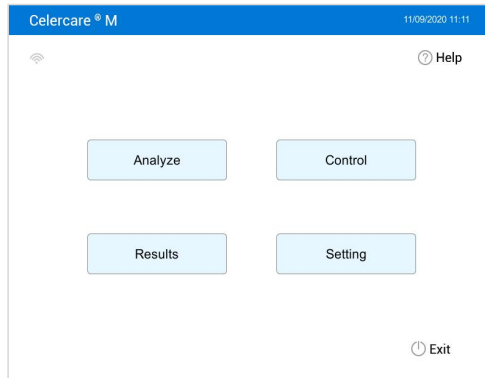

- b. Then press ‘**Date/Time**’.

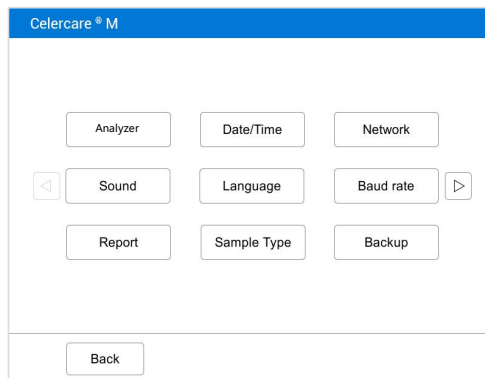

- c. The display will show the Set ‘**Date/Time**’ screen. Automatically synchronize network time when the network is connected.

Select year, month and day on the calendar, input the hour, minute and second. Press ‘**Save**’ when Date/Time is set.

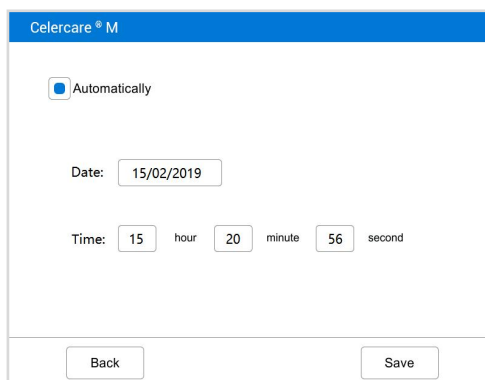

5.3 Network Connection

The analyzer has a built-in Wi-Fi module, connecting Wi-Fi can help you automatically download the new version of the software upgrade or uploading error logs to the Cloud server. Technical support engineers will review the error log to diagnose the analyzer’s problem.

- a. On the Main screen, press ‘**Setting**’.

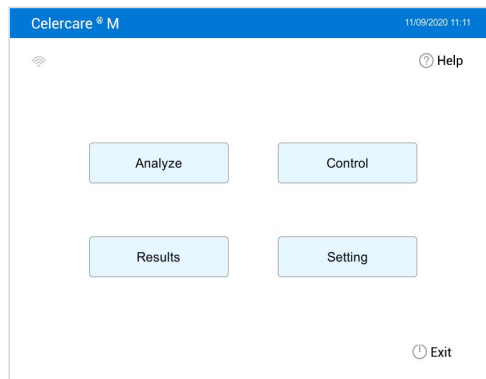

- b. Then press ‘**Network**’.

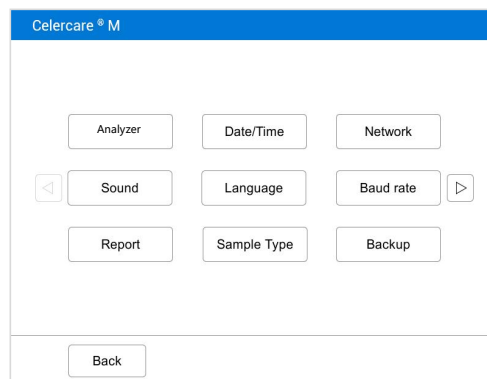

- c. Press ‘**Scan**’ to display the network list. Choose a wireless network and press the name of the network you want to connect to.

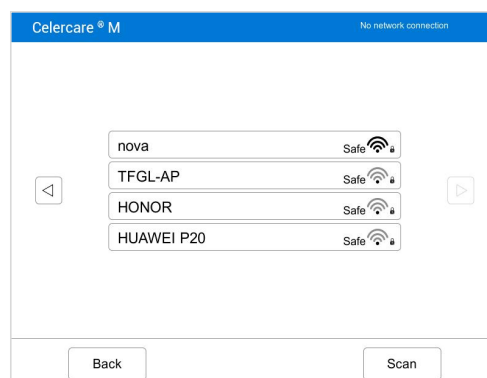

- d. If you are connecting to a secured network, input the password. Then press ‘**Connect**’.

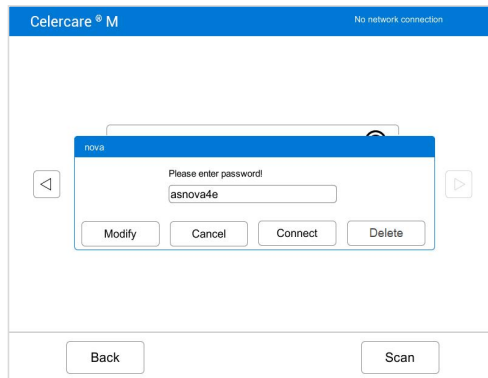

- e. The displays shows the following.

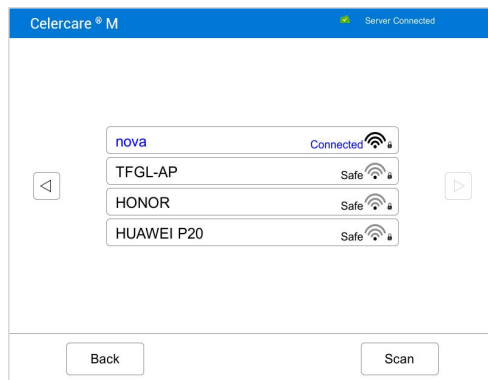

5.4 Setting Sound

- a. On the Main screen, press ‘**Setting**’, then press ‘**Sound**’.

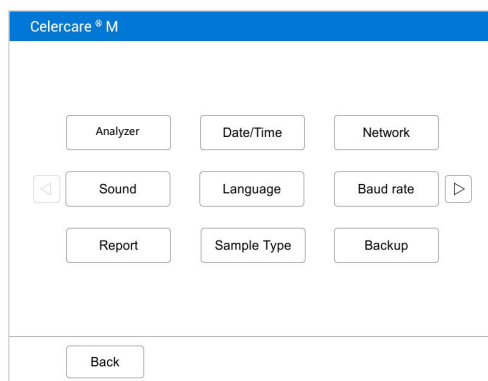

- b. The user can select ‘**Sound**’, ‘**Silent**’, or ‘**Key tone**’. The ‘**Sound**’ refers to the prompt tone of opening the analyzer and finishing the analysis. The ‘**Key tone**’ is the prompt tone for pressing the buttons.

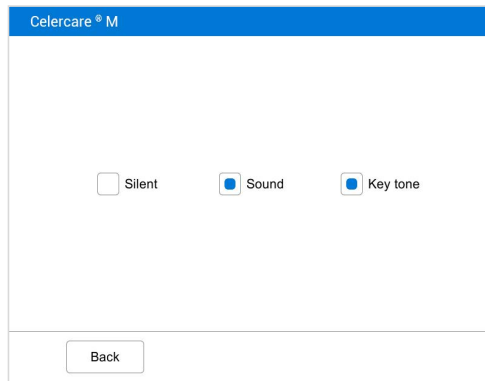

5.5 Setting Language

- a. On the Main screen, press ‘**Setting**’, then press ‘**Language**’.

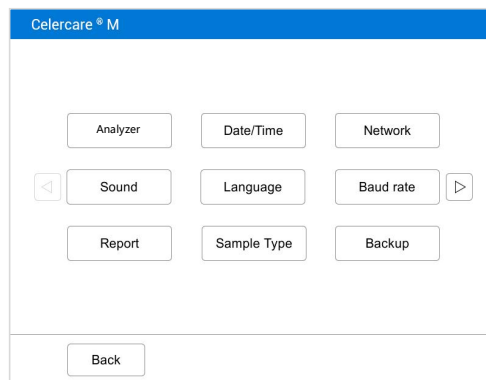

- b. The user can select the language required.

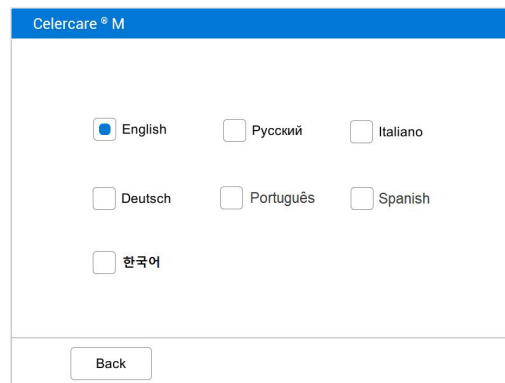

5.6 Baud Rate

A data transmission rate (bits/second) for modems, used to communicate with hospital LIS system and MMDMP (See Section 8)

- a. On the Main screen, press ‘**Setting**’, then press ‘**Baud rate**’.

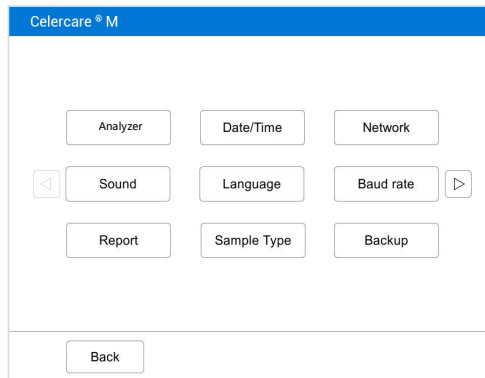

- b. The user can select one mode. The default value is **115200**.

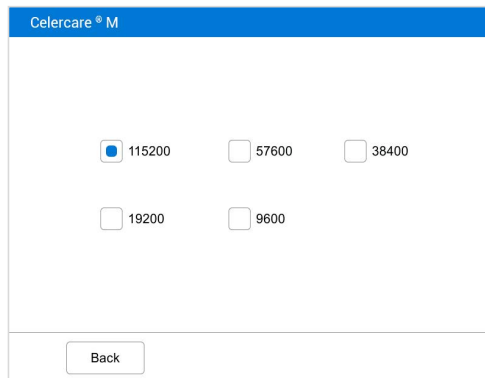

5.7 Report Layout

Using the Report Layout feature, the operator can set the reported content as needed.

5.7.1 Basic information: Hospital Name

- a. On the Main screen, press ‘**Setting**’, then press ‘**Report**’ → ‘**Basic information**’ → ‘**Hospital Name**’.

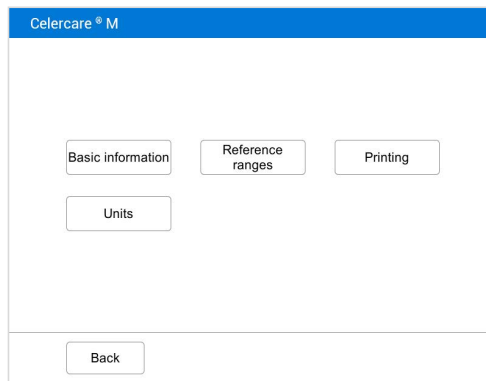

- b. Enter the hospital name to be displayed on the report. Then, enter the telephone number and the distributor company, press **‘Back’**.

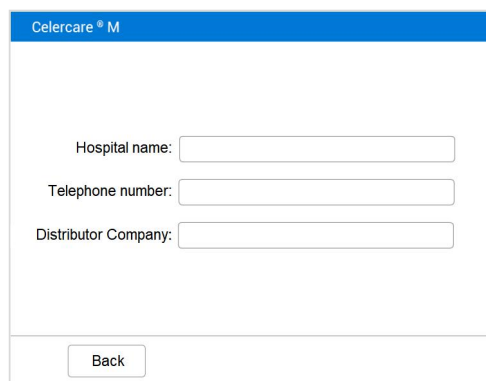

5.7.2 Reference Ranges

The analyzer includes a number of factory-set analyte and demographic reference ranges for use in analysis. The operator can modify these ranges as needed, as well as create or remove custom ranges, or return all factory ranges to their default settings.

- a. On the Main screen, press **‘Setting’** → **‘Report’** → **‘Reference ranges’**.

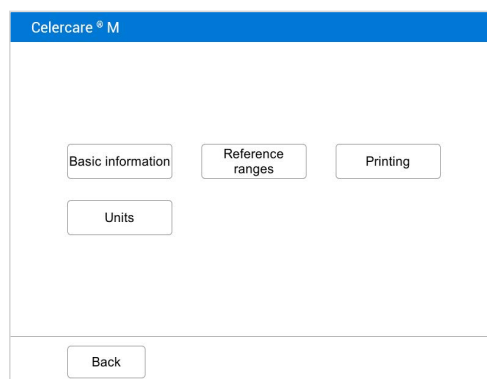

b. Then select ‘Male’ or ‘Female’ or ‘Other’.

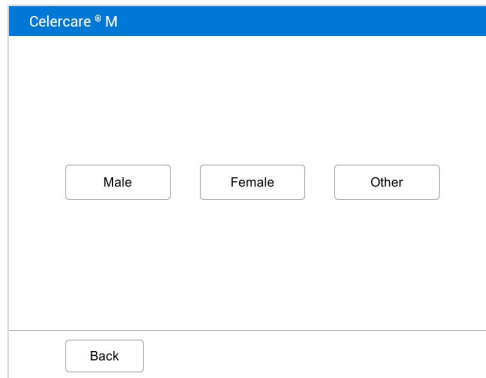

c. Then select ‘Adult’ or ‘Child’ to show the parameters list.

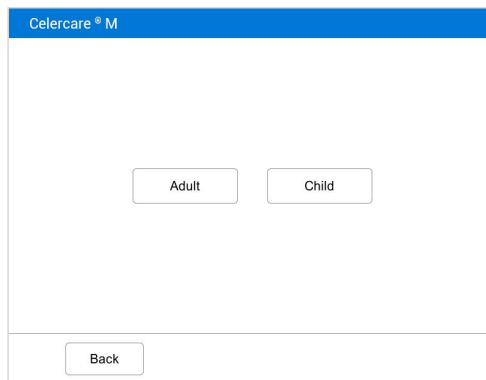

d. Use ‘◀’, ‘▶’, to go through the list. Press the square with numbers to show the soft keyboard and use it to input new lower and upper limits for the range. Press ‘Save’ to store the changes.

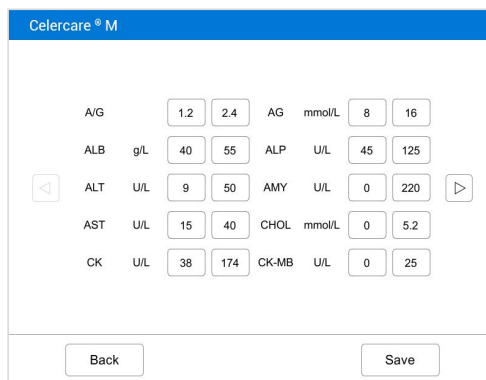

e. If you select ‘other’ in the second step, the interface appears. The reference range is blank and the value needs to be confirmed by the doctor.

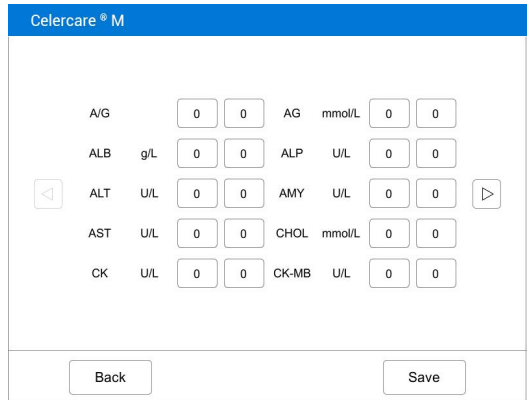

5.7.3 Units

- a. On the Main screen, press **'Setting'** → **'Report'** → **'Units'**.

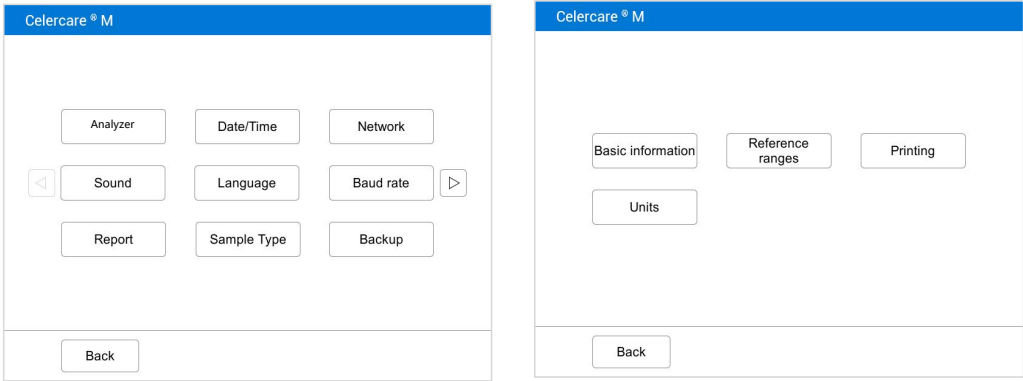

- b. Select the unit to be displayed on the report.

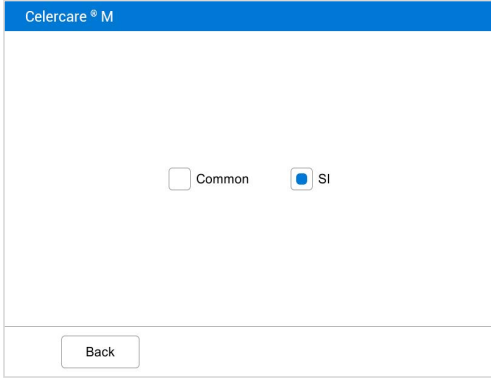

5.8 Sample Type

- a. On the Main screen, press **'Setting'**, then press **'Sample Type'**

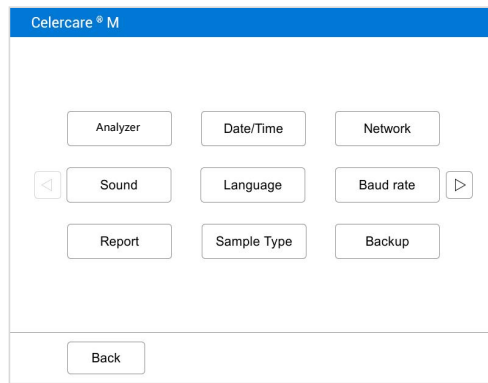

b. The user can select **‘Whole blood’**, **‘Serum’** and **‘Plasma’** testing mode.

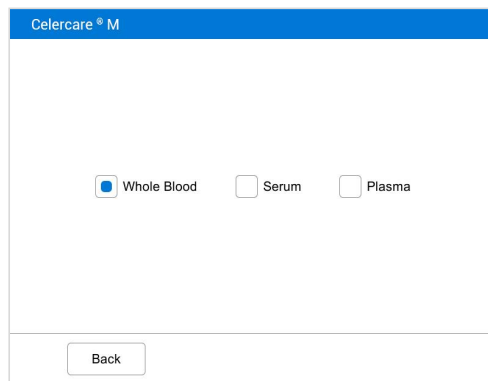

5.9 Permission Management

The permission management accounts are divided into two types: administrator accounts and regular accounts. Administrator permissions allow login to the device, adding or deleting regular user accounts, modifying passwords for all accounts, and viewing test records under all accounts; regular user permissions allow login to the device and viewing test records under their own account.

5.9.1 Enable the ‘Permission Management’ feature.

- a. On the main interface, click on ‘System Settings’, then navigate to the ‘Permission Management’ button. Check the box for ‘Enable Permission Management’, click ‘Yes’ to confirm, and proceed to the administrator account registration interface.

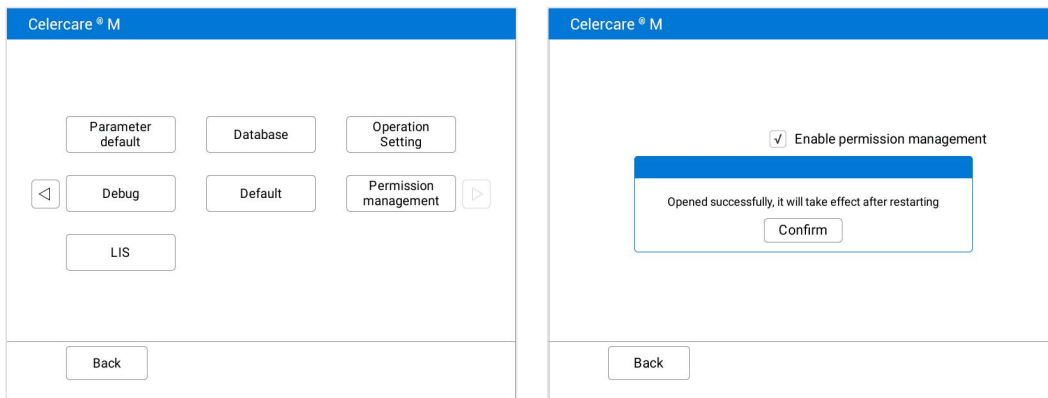

- b. The default administrator account name is ‘admin’ (which cannot be changed). Enter the password and confirm it, then click the ‘Save’ button. A popup will appear indicating that the ‘Permission Management’ has been successfully enabled. Click ‘Yes’ to restart the device. After the device restarts, the ‘Permission Management’ feature will be activated automatically.

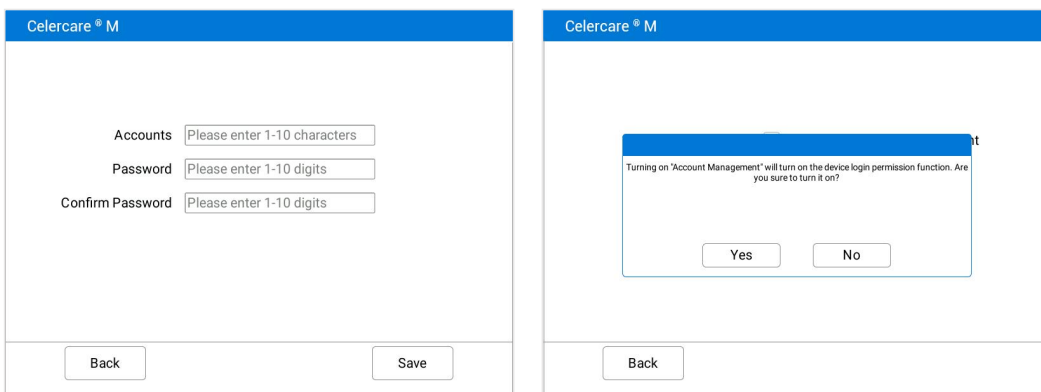

Note: It's crucial to securely store the administrator account password; once lost, it's irretrievable.

5.9.2 Account login and account switching

- a. Once **‘Permission Management’** is activated, the device will display the account login interface upon startup. Click on the blank box next to **‘Account’**, select the desired username, enter the corresponding password and click the **‘Log in’** button to access the main interface of the device.

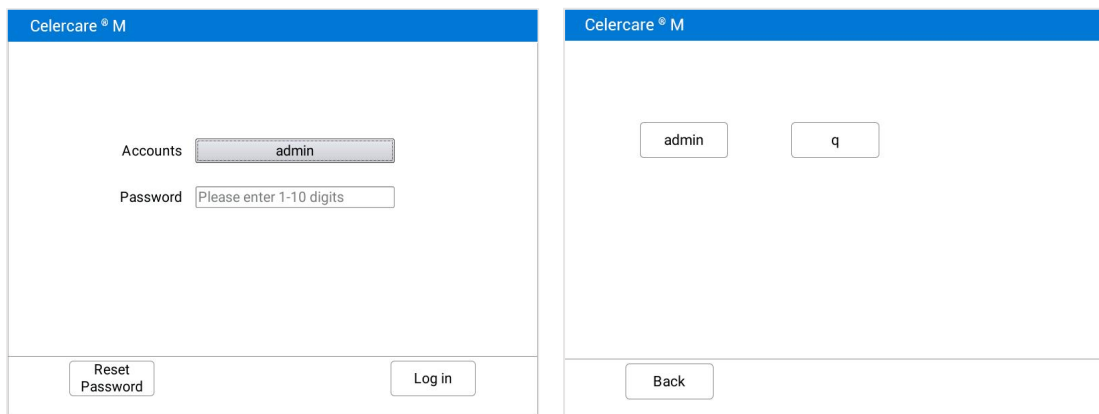

- b. The current account name is displayed in the upper right corner of the device's main interface. To switch accounts, click the **‘Switch Account’** button in the lower left corner. You can then select a different username and enter the password to log in.

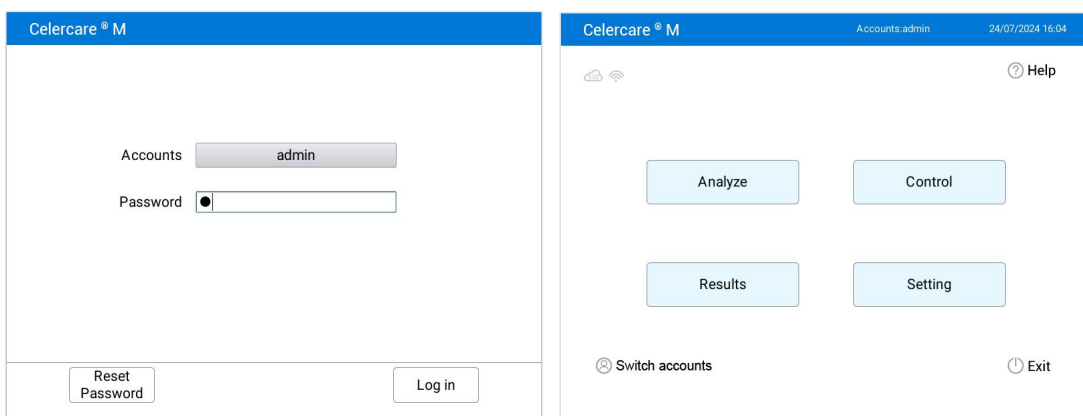

5.9.3 Administrator Account Password Modification

- a. On the account login interface, click the **‘Change Password’** button in the lower left corner. Enter the original password, click **‘Yes’**, and you will be taken to the password modification interface.

The image shows two screenshots of the Celercare M login interface. The left screenshot displays the login form with the 'Accounts' field containing 'admin' and the 'Password' field with the placeholder 'Please enter 1-10 digits'. Below the form are 'Reset Password' and 'Log in' buttons. The right screenshot shows a confirmation dialog box with the text 'Please enter the administrator password' and a password field, with 'Yes' and 'No' buttons below it. Below the dialog box are 'Reset Password' and 'Log in' buttons.

- b. Enter the new password and confirm it, then click the ‘Save’ button in the lower right corner. The administrator account password has been successfully modified. Please use the new password for subsequent logins.

The image shows a screenshot of the Celercare M account management interface. It features three input fields: 'Accounts' with the placeholder 'Please enter 1-10 characters', 'Password' with the placeholder 'Please enter 1-10 digits', and 'Confirm Password' with the placeholder 'Please enter 1-10 digits'. At the bottom of the form are 'Back' and 'Save' buttons.

5.9.4 Standard account management: adding, removing and editing of account information

- Access the ‘Settings’ → ‘Permission Management’ interface using either an Administrator or a Standard account.
- Click the ‘Edit Account’ button, input the Administrator password, and click ‘Yes’ to enter the account editing interface.

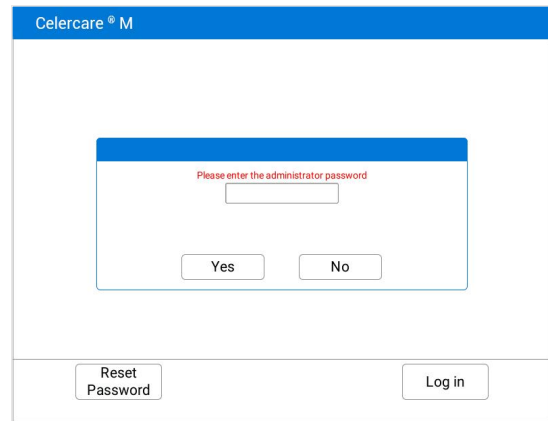
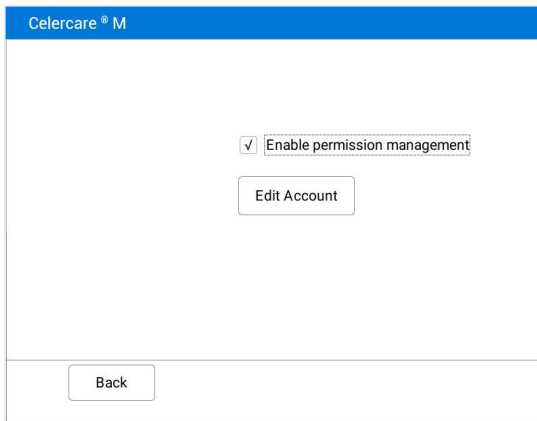

- c. In this interface, you can add or delete Standard accounts or change passwords of Standard accounts.

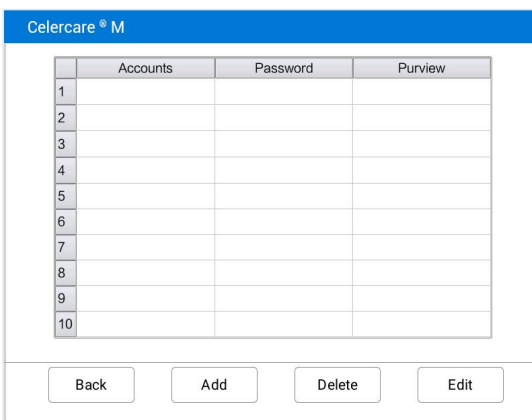

5.9.5 Deactivating the Permission Management function

- a. Under any account (administrator or regular account), go to ‘System Settings’ → ‘Access Control’ interface, and uncheck the ‘Enable Access Control’ option.

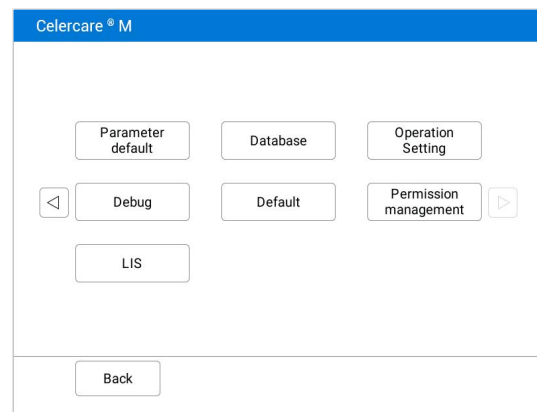
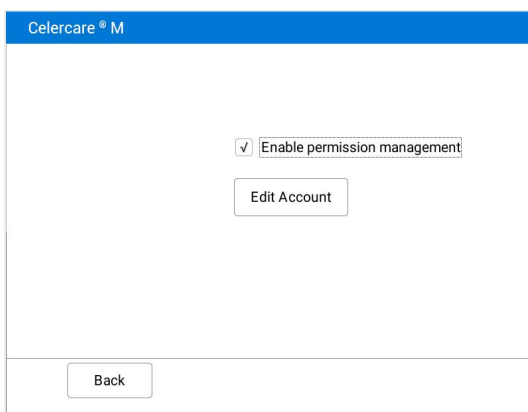

- b. Enter the administrator password and click ‘Yes’ to disable the ‘Access Control’ function. The change will take effect after the device restarts.

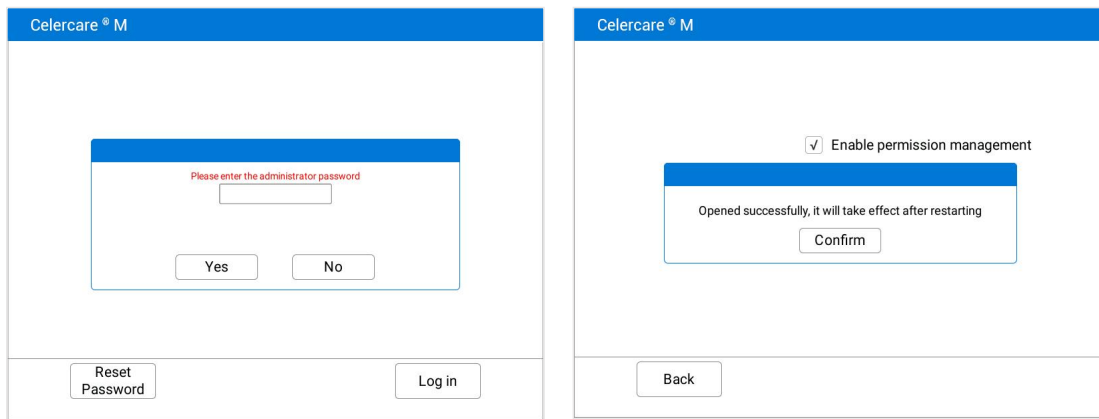

5.10 Setting LIS Function

The device can connect to LIS via serial cable, Ethernet (using the device's network port), or wirelessly (Wi-Fi, internal local area network).

The prerequisites for this functionality are:

- a. The device is correctly connected to the Ethernet or wireless network.
- b. The device's IP address is reachable from the LIS server IP.
- c. The LIS system must have the capability to receive data over the network (our company can provide the LIS protocol documentation and the HTTP LIS integration protocol documentation, with the LIS vendor responsible for integration and establishing LIS system functionality).

Click the ‘**System Settings**’ button on the main interface, then click the ‘**LIS**’ button.

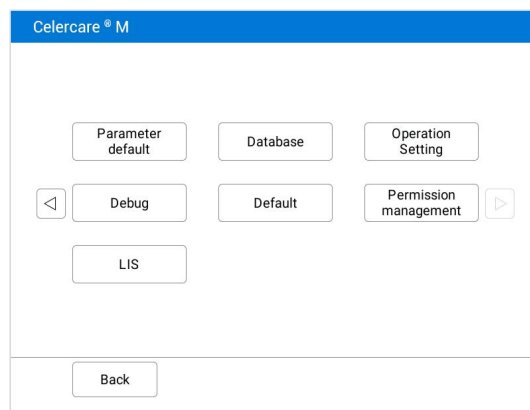

After selecting the communication method as ‘**TCP SOCKET**’ or ‘**HTTP POST**’, the ‘**Device IP**’ will be displayed automatically. Then, the LIS engineer

will complete the ‘**Target IP**’ and ‘**Target Port Number**’ (referring to the IP and port of the LIS server).

Celercare® M

TCP SOCKET HTTP POST

Local IP:

Target IP:

Target Port:

Note: If the customer's environment does not have DHCP functionality, the ‘Device IP’ will not be displayed automatically and must be entered manually.

After filling in the information, click the ‘**Connect**’ button in the upper right corner.

If the connection is successful, a message will appear on the screen stating ‘**Successfully connected**’ and it will automatically connect next time. After a successful connection, the icon on the main interface will be illuminated.

Celercare® M

TCP SOCKET HTTP POST

Successfully connected

Local IP:

Target IP:

Target Port:

5.11 Operation Settings

On the main interface, select ‘System Settings’, then click the ‘Operation Settings’ button. In the resulting interface, there are options for ‘Tear Blue Film Reminder’ and ‘Water Tray Reminder’. Click the checkbox in front of the corresponding option; a blue square will appear in the checkbox to indicate selection. This will prompt relevant operations during the procedure.

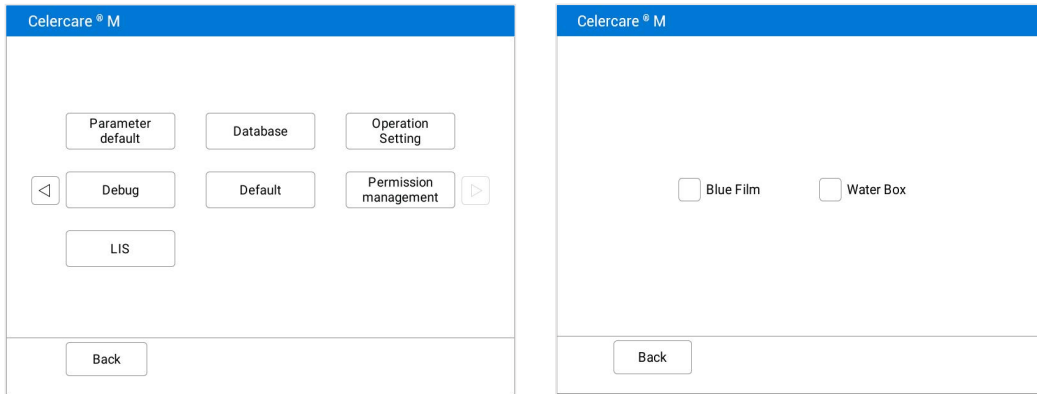

5.12 Backup

This feature allows backing up of the analyzer's operation logs to a USB drive, facilitating problem resolution later.

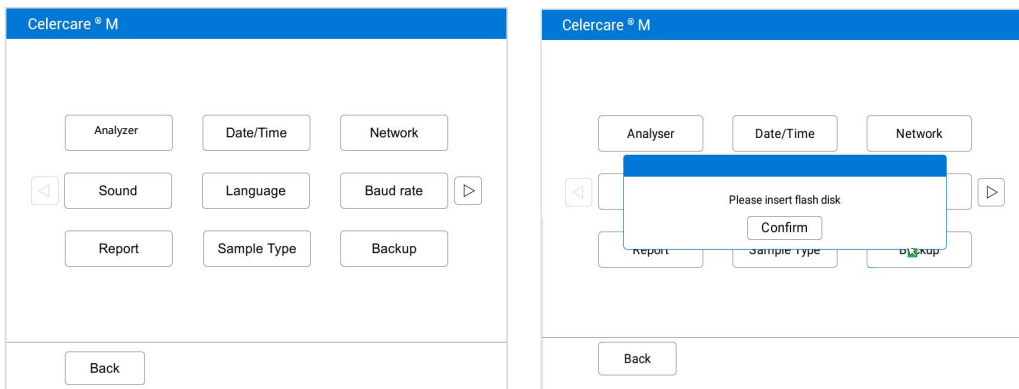

5.13 Other Settings

In the settings, clicking on 'Parameter Default', 'Database', 'Debug', 'Default' requires entering a password before any adjustments can be made.

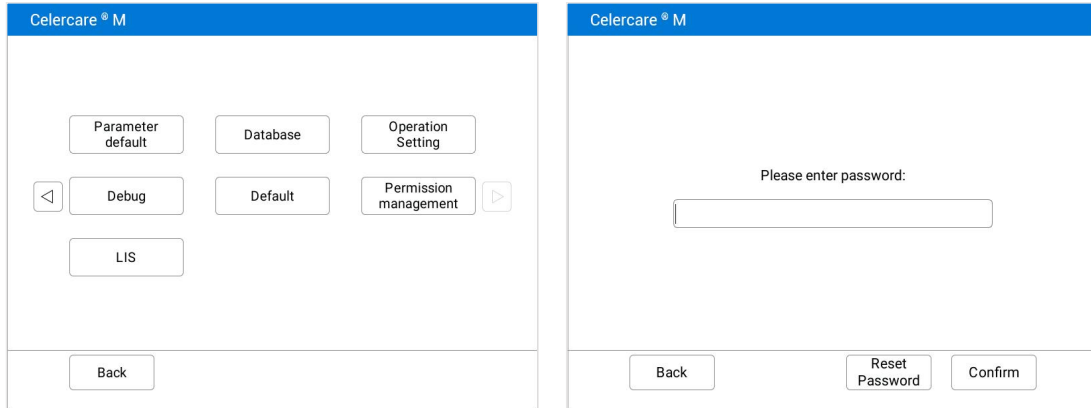

- Parameter default: Restore to the factory settings in 'Settings'.
- Default: Restore factory settings to clear all data from the analyzer.
- Database: Backup or delete the database.
- Debug: Debugging for factory parameters of the device.

Section 6 Troubleshooting

6.1 Electrostatic Discharge

If the analyzer experiences an electrostatic discharge while running a sample, it may cause the system to ‘Crash’. The test should be cancelled immediately once the test times out (or countdown timer stops). Then turn the analyzer off and back on after a few minutes. The analyzer will return back to normal after this operation.

6.2 Error Codes for the Analyzer and Troubleshooting

The analyzer can display warning and error codes when problems occur. These error codes will assist MNCHIP Technical Support in diagnosing the problem. Before contacting MNCHIP technical support, update the log and provide the serial number.

Error code	Problem Description	Solution
0101	Multi-switch fault	<p><i>Please contact us if you have any enquiries.</i></p> <p><i>E-mail:</i> <i>service@mnchip.com</i></p> <p><i>Refer to the Maintenance Manual (Authorized dealers only)</i></p>
0102	+12V power fault	
0103	-12V power fault	
0105	AD (AD fault)	
0107	Optical module fault	
0108	LED fault	
0202	Drawer open fault	
0203	Drawer close fault	
0206	Motor speed fault	
02132~02135	Temperature control module fault	
0214	Optical components contamination	
0215	Software error	
0216	Software error	
0220	Temperature data transmission fault	
0221	PT100 fault	
0222	Upper NTC fault	
0223	Lower NTC fault	

0224	Upper heating film fault	
0225	Lower heating film fault	
0301	Firmware 2 fault.	
0302	Scan module fault	
0303	Firmware 1 fault.	

6.3 Common Error Codes for Reagent Discs and Troubleshooting

Error Code	Problem Description	Solution
02081	Insufficient sample	<i>According to Section 3.3 operation requirements, add correct sample and diluent volumes, repeat the analysis with a new reagent disc</i>
0233	The diluent container is not opened properly	
0210	Reagent disc fault	
0211	Reagent disc fault	
02133	The temperature control system fault	<i>Please check whether the ambient temperature range is 10-30 °C</i>
02134	The temperature control system fault	<i>Please clean or replace the dust-proof sponge</i>
0231	Hemolysis	<i>Please collect a new sample for testing</i>
0232	Lipemia	<i>Recommend repeating the analysis with a new disc after high speed centrifugation of the sample</i>
0234	Reagent disc fault	<i>Please repeat the analysis with a new reagent disc</i>
0238	Reagent disc fault	<i>Please repeat the analysis with a new reagent disc</i>

Section 7 Maintenance

The analyzer requires minimal maintenance. Clean the outside of the analyzer weekly with a mild detergent and a soft, damp cloth. The air filter needs to be cleaned once every month. Regular maintenance of the analyzer ensures reliable operation.

7.1 Cleaning the Analyzer

7.1.1 Cleaning the Case

Clean the analyzer with a soft cloth, dampened with a mild, non-abrasive detergent or cleaning solution, a 10% bleach solution or a 30% isopropyl alcohol solution. Do not spray or pour any detergents, solutions or other liquids directly onto the analyzer.

7.1.2 Cleaning the Display

Clean the analyzer's screen using a soft, lint-free cloth dampened with a glass-cleaning fluid or window cleaner. The screen can be disinfected using a 10% bleach solution: apply the solution to a lint-free cloth and then wipe the screen.

Note: Do not use any cleaner containing alcohol. Do not spray cleaner directly onto the display — dampen the cloth instead.

7.2 Cleaning the Air Filter

The air filter at the rear of the analyzer should be cleaned once per month. Check the air filter more often than once per month if the analyzer is located in an environment with excessive dust or dirt. To clean the air filter:

- a. Unplug the analyzer and remove the power cord from the rear of the analyzer.
- b. Open the fan cover and remove the black mesh filter.
- c. Wash the filter in warm soapy water and dry completely.
- d. Place the clean, dry filter back on the fan and tighten the fan cover.
- e. Plug the power cord into the rear of the analyzer.
- f. Plug the power cord into the power source.

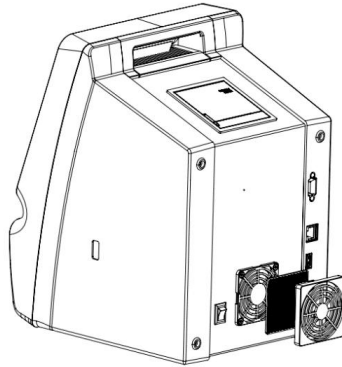

7.3 Updating the Analyzer Software

MNCHIP provides software updates to registered analyzers through the server. Whenever a new software version is released, it will be uploaded to the MNCHIP server immediately.

7.3.1 Automatic Update

- a. Connect to a WI-FI network following the procedure in **Section 5.3 Network Connection**.

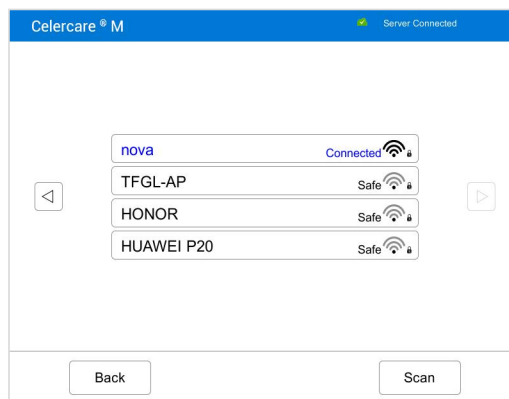

- b. A 'new version' window will pop-up automatically when a new version of the software is available.
- c. Press 'Yes' to confirm.

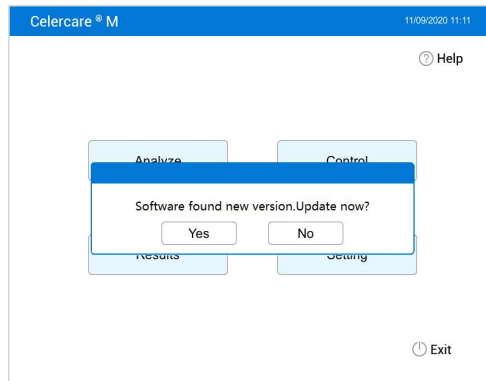

- d. When updated successfully, press ‘Confirm’ and the analyzer will reboot.

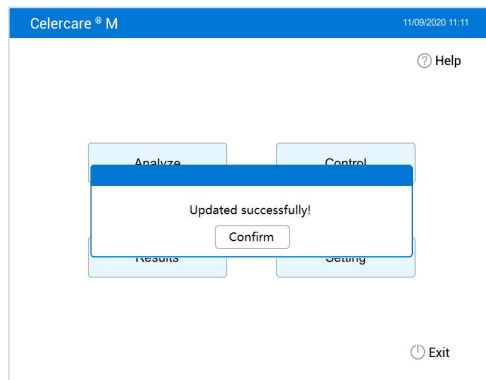

7.3.2 Manual Update

- a. Connect to a WI-FI network following the procedure in **Section 5.3 Network Connection**.

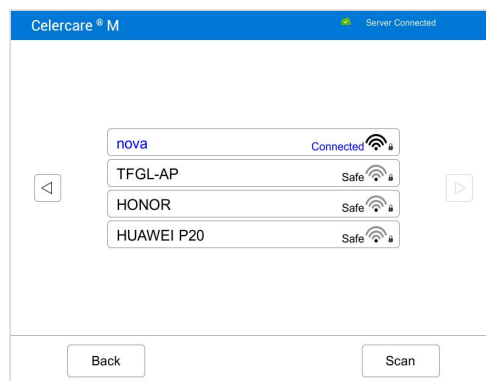

- b. On Main Screen, press ‘Setting’, and then press ‘Analyzer’.

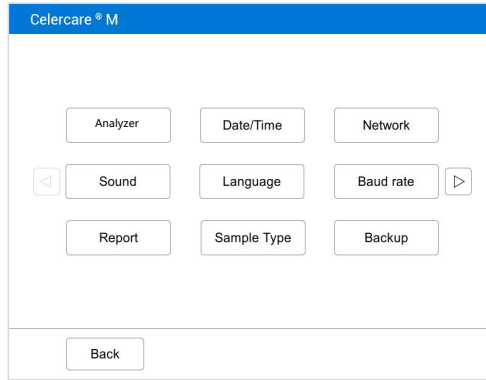

- c. The analyzer information page will display. Press ‘Update’ to update the software version or one of the hardware versions.

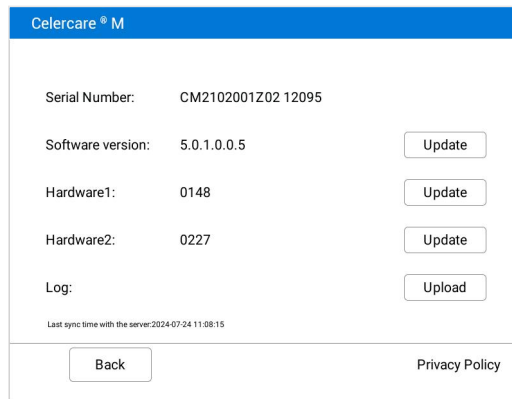

- d. A ‘new version’ window will pop-up, press ‘Yes’ to confirm. When updated successfully, the analyzer will reboot.

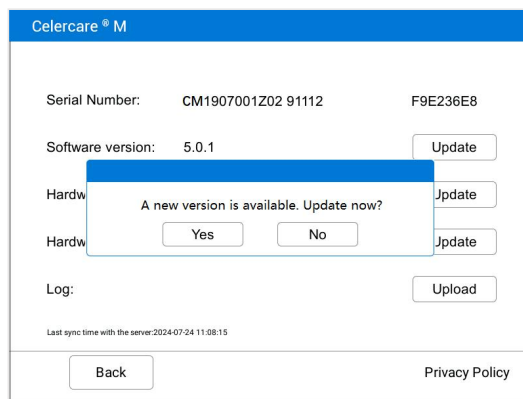

Caution: Do not disconnect the network or turn off the analyzer before the update is complete.

7.3.3 USB Drive Update

- a. As an alternative method, the operating system can also be updated via the USB drive.



- b. Please contact MNCHIP technical support to receive the software via email. Please copy the software to the USB drive, create a file on the USB called ‘updatesoft’ and save the upgrade under this file. Such as:

K:\updatesoft\Celercare M5_arm.7z.

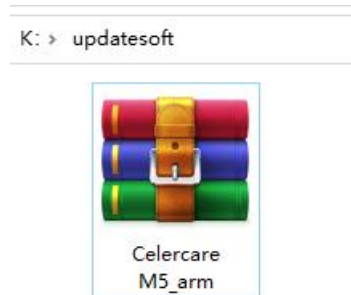

- c. Plug the USB disk to the USB port at the rear of the device.

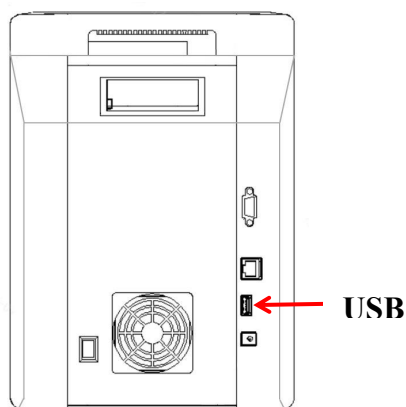

- d. On the Main Screen, press ‘Setting’, then press ‘Analyzer’

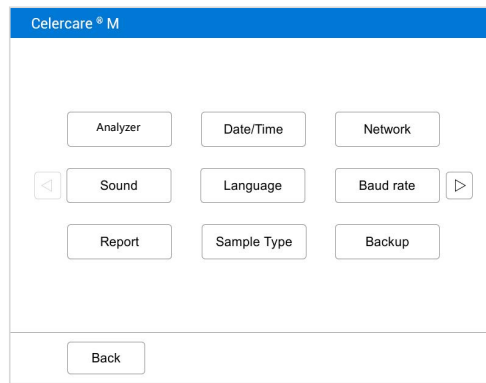

- e. The analyzer information page will display. Press **‘Update’** to update the software version.

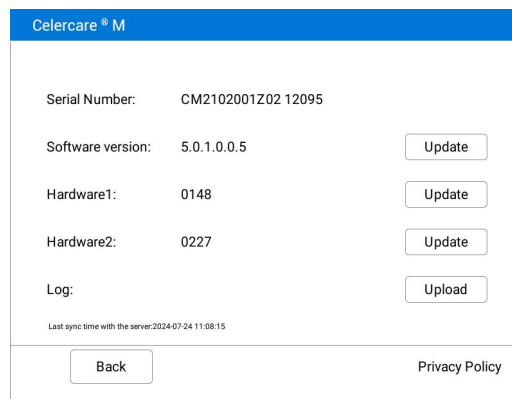

- f. A ‘new version’ window will pop-up, press **‘Yes’** to confirm, then waiting for update.

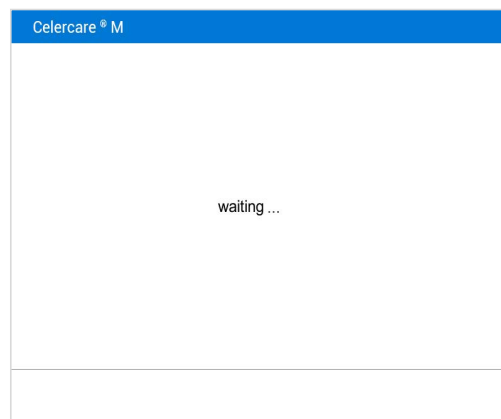

- g. When updated successfully, press **‘Confirm’** and the analyzer will reboot.

Caution: Please do not insert the USB drive anywhere except the device to avoid virus infection.

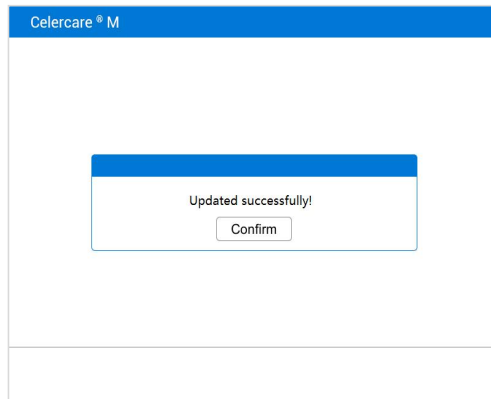

7.4 Software Recovery

If the analyzer displays a recovery screen when the power is turned on, it means that the software has some basic files missing. You can use the USB drive or network to restore the system. If recovering via network, only the latest version can be restored.

Using USB recovery, it will only restore to the corresponding stored version. It is also recommended to get the latest version.

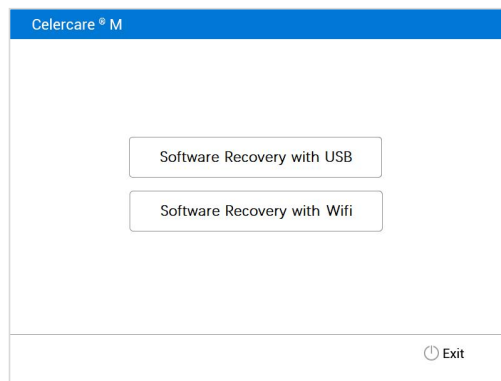

7.4.1 Wi-Fi Recovery

- a. When the user needs to restore the system through the wireless network, click the '**Software Recovery with Wi-Fi**' button. The "**Wi-Fi Recovery**" screen will display the available wireless network resources.

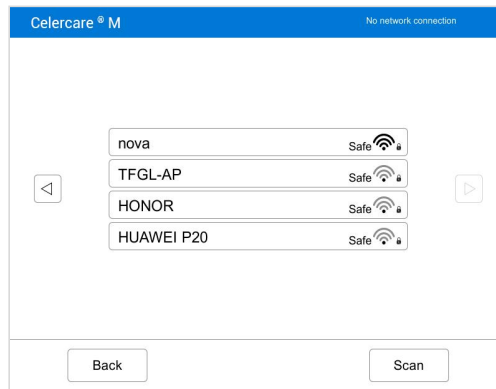

- b. When the network connection is successful, the ‘**Recovery**’ button will appear in the upper right corner of the screen. Click the ‘**Recovery**’ button.

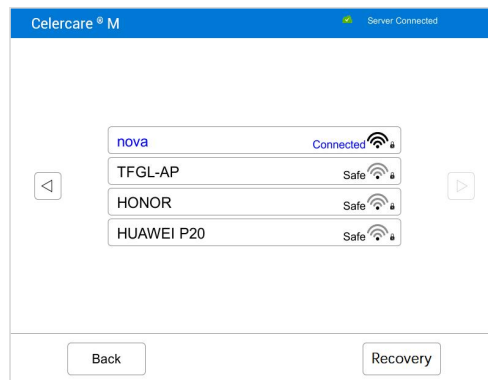

- c. The analyzer will download the system program and automatically restart it upon completion.

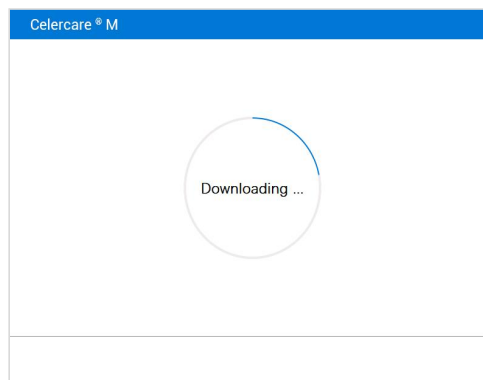

- d. If the analyzer can reboot normally and display Main screen, the system is successfully restored. If the above does not solve the problem, please contact us.

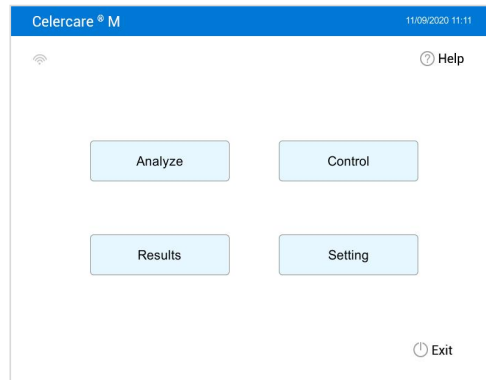

7.4.2 USB Drive Recovery

- a. As an alternative, the operating system can also be recovered via a USB drive, please contact MNCHIP Technical Support to receive the software via email. After downloading the software, please copy the software to a USB drive. Refer to **Section 7.3**.
- b. Click the '**Software Recovery with USB**' button.

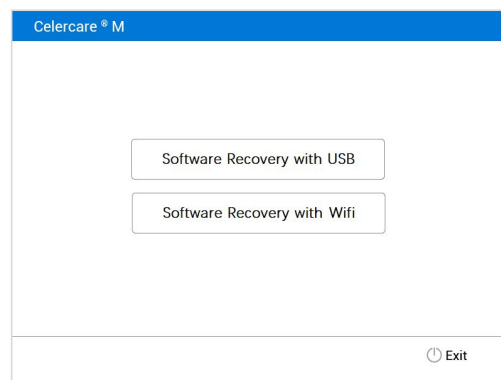

- c. The USB flash recovery mode is displayed on the screen and the USB drive is inserted into the USB port on the back of the device. Click '**Recovery**' in the upper right corner of the interface, the analyzer will automatically recover and reboot after completion.

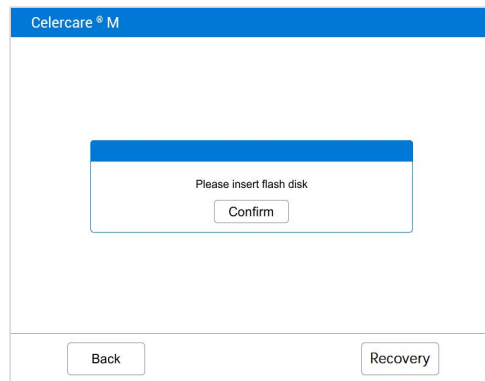

- d. If the analyzer can reboot normally and display the Main screen, the system is successfully restored. If the above does not solve the problem, please contact us.



7.5 Installing Thermal Printer Paper

- Open the printer cover.
- Remove the thermal paper package and remove a few centimeters of paper.
- Place the paper in the printer in the direction shown with the non-printing surface in contact with the rubber roller.
- Close the printer cover and make sure to expose a few centimeters of paper.
- Remove the exposed paper.

Note: After installation, the thermal side of the paper should face down. If the paper is installed incorrectly, it will not print the report.

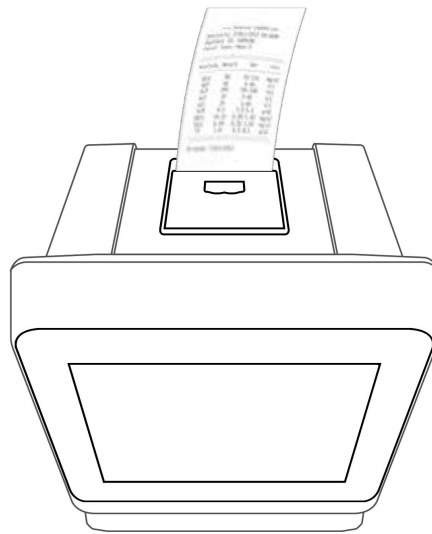

Section 8 MNCHIP Medical Data Management Platform

8.1 MMDMP

The MNCHIP Medical Data Management Platform (MMDMP) is software that runs on Windows and interfaces with the MNCHIP Automated Chemistry Analyzer. It is primarily responsible for receiving and managing data from the analyzer. Basic functions include hospital name settings, language selection, patient information editing, result query and printing, printer settings, test results export and more.

8.2 Installing the MMDMP

8.2.1 How to get the software

The MMDMP installer is available on the MNCHIP website as follows:

- Logon the web <http://www.mnchip.com>
- Go to the Reference Center.
- Download the MMDMP.

Note: Obtain from the after-service engineer if the above method is not convenient.

Contact: send E-Mail: service@mnchip.com

8.2.2 Setting up the MMDMP

Note: Some anti-virus software may affect the installation. For the installation process, it is recommended to turn off anti-virus software.

Note: The MMDMP can be installed on the system of Windows7, Windows8, Windows10, Windows11. Please do not install on Windows XP, otherwise it may cause some errors.

- a. Start the installer and the installation prompt will appear. Please select the installation language and then press 'OK'.

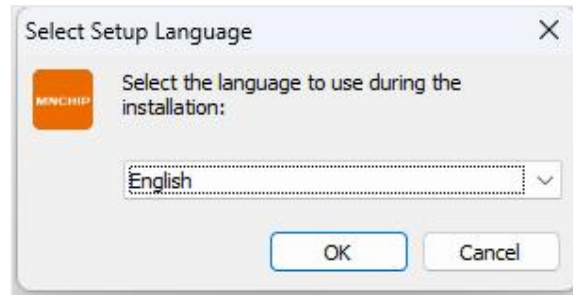

- b. Confirm whether to create a shortcut for the management platform software on the desktop. If you want to create it, please check **‘Create a desktop shortcut’** and click 'Next' to proceed.

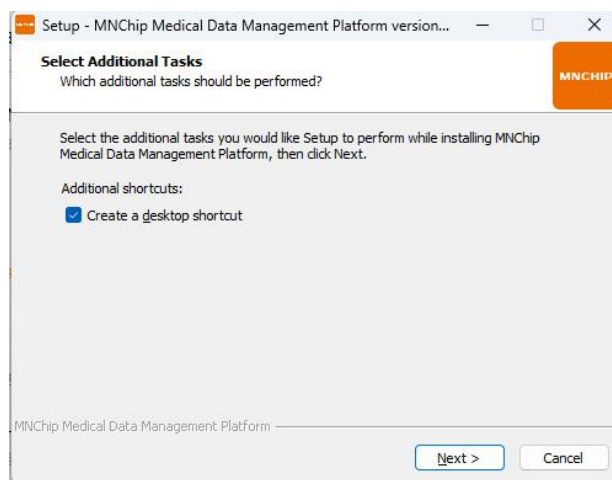

- c. Enter the installation interface and select **‘Install’**.

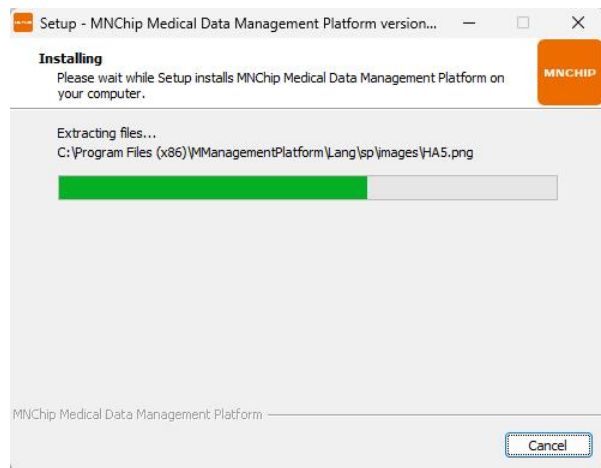
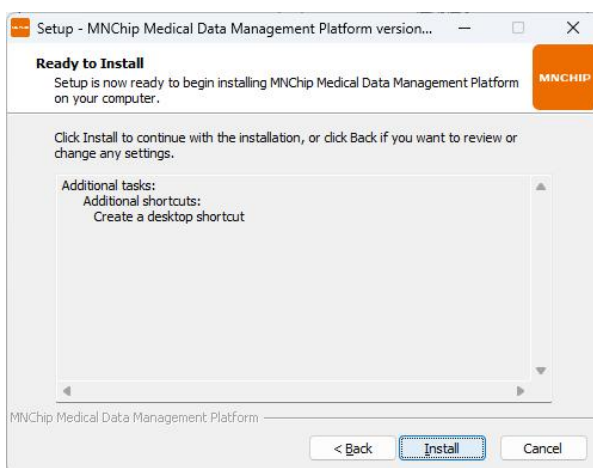

- d. After the installation is complete, a confirmation dialog will pop up, click **‘Finish’** to complete the installation.



Note: When the installation has finished, there will be a shortcut on the desktop of the PC.

8.3 Login

Open the 'MNCHIP Medical Data Management Platform' and enter the 'Login' interface.

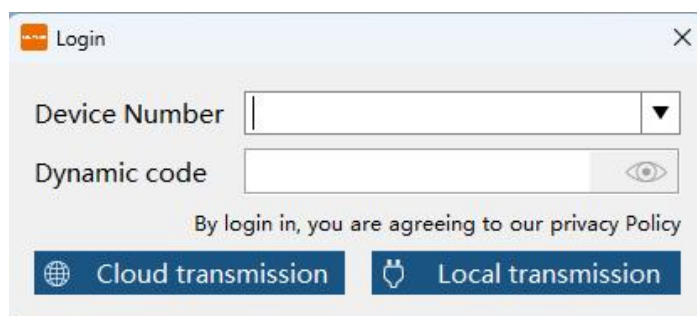

8.3.1 Local transmission

Use the data cable to connect to the chemistry analyzer and PC. There is no need to enter any information, click '**Local transmission**'.

Note: Before connecting via the data cable, make sure the analyzer is powered off or rebooted after the connection, otherwise data transfer is not possible.

8.3.2 Cloud transmission

When using cloud transmission, the chemistry analyzer and the PC with MMDMP must be networked. The device transmits data to the cloud server through WI-FI and the MMDMP software downloads the data from the server to the PC. To view the device ID and login password, go to '**Setting**' → '**Analyzer**'

in the chemistry analyzer, enter the complete device ID and login password in the MMDMP and click ‘Cloud transmission’.

Note: When you open the management platform software again, click ‘Cloud Login’. The software will default to the previously matched device.

Note: If the ‘Device Info’ does not display login password, then it indicates that the device has no Internet access. Please return to the ‘Setting’ → ‘Network’ to reconnect to the network

8.4 ‘Main Screen’ Description

The main interface of MMDMP is divided into four functional areas. Please refer to the yellow symbols in the figure below. Shortcut toolbar ①, for data interface selection and connection, data backup and lookup, setup and help. Inspection information area ②, displaying the currently selected patient information and modifying the related information. The data selection area (patient info) ③ is mainly used for selecting a patient report to be printed. The data display area (Result) ④ is mainly used to report the selection and ranges of the printed content.

When the test result is within the reference range, the background is ‘light yellow’; when the test result is lower than the lower limit of the reference range, the background is ‘blue’; when the test result is higher than the reference range the upper limit is ‘red’; If you combine the results of different test equipment, the results of adding other types of equipment (not the results of this chemistry analyzer), the background is ‘dark yellow’, each column can be edited.

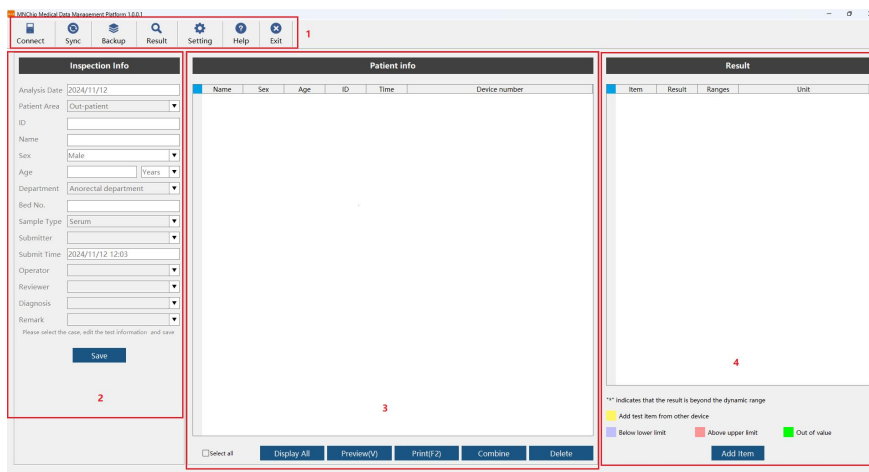

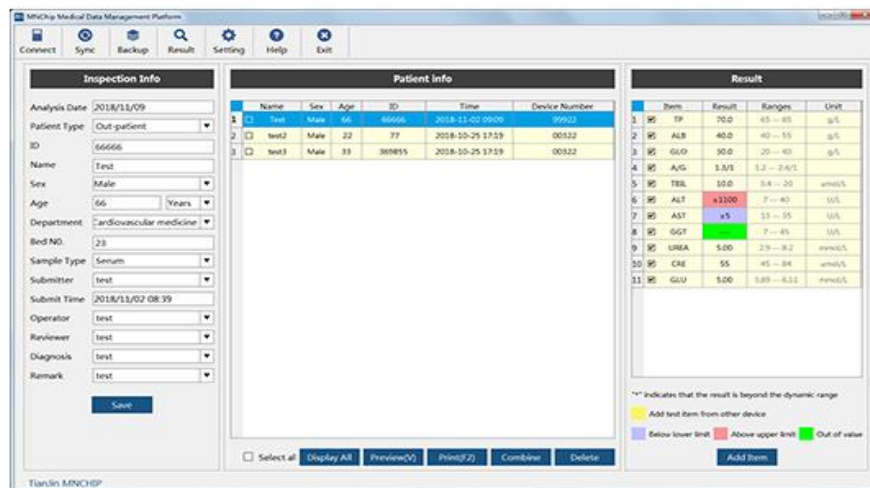

8.4.1 Inspection Info

Display the patient information of the corresponding record, you can edit it, click 'Save' to save the modified 'Test Information'.

8.4.2 Patient Info

The test record matching the query is displayed, and the test record of the day is displayed by default.

- Click 'Select All': select all test records.
- Click 'Display All': display all test records.
- Click 'Preview': Preview all selected test record reports or click 'Quick Export' to export PDF.
- Click 'Print': print the selected test report, select the printer and set the print, then click 'OK' to print. Click 'Close' to modify the report form or cancel printing.
- Click 'Combine': Merge selected test records and generate new test records. Click 'Delete': cancel the selected test records.

8.4.3 Result

The patient test results corresponding to the selected test record are displayed.

- Modify test results: This function can be used by the operator to modify the test results of certain items. Double-click the test value to modify the test results.

- ‘Add Test Items’: add other test items.

8.5 Settings

Click ‘Setting’ in the.

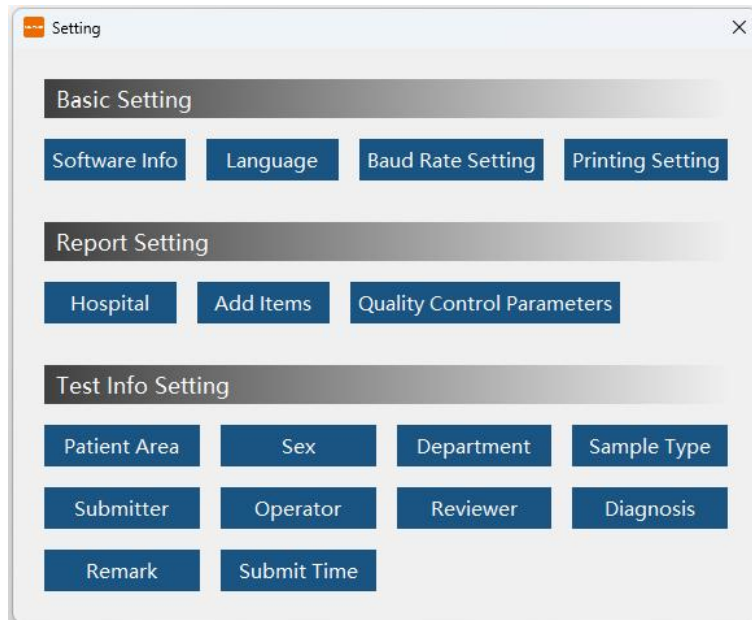

8.5.1 Basic Setting

- Software Info: show the information of the software, click ‘Software update’ to upgrade the software.



- Language: select the language.

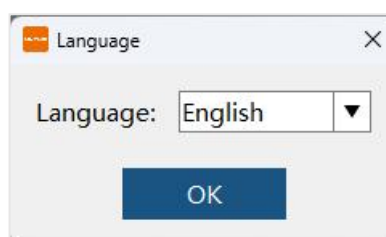

- c. Baud Rate Setting: set the baud rate for data transmission under ‘Wired Login’.

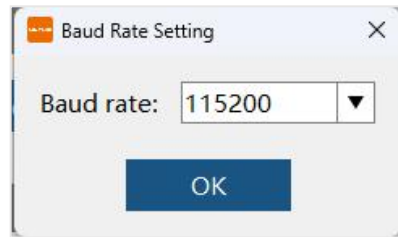

- d. Printing Setting:

- A5 Protrait Print: place A5 paper with a width of 14.8 cm and a height of 21 cm in the printer to print a report sheet.
- A5 Landscape Print (default): place A5 paper with a width of 21 cm and a height of 14.8 cm in the printer to print a report sheet.
- A4 Print: place A4 paper in the printer to print the report sheet.

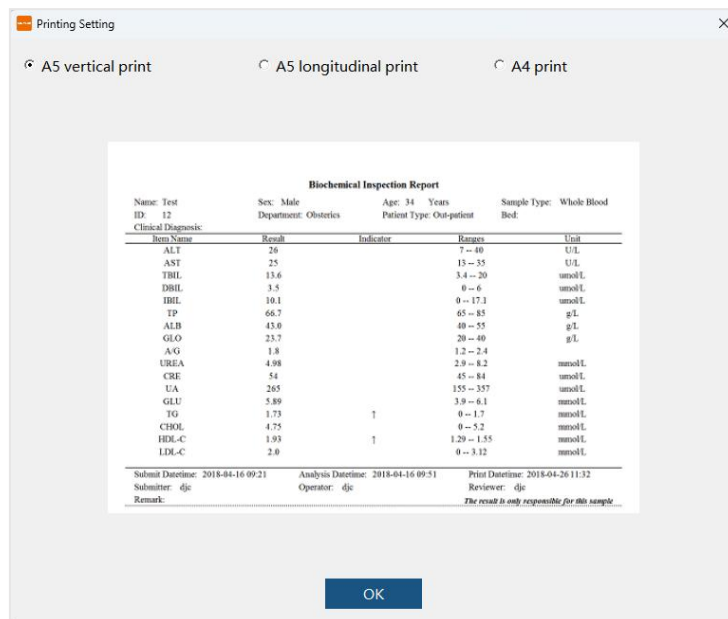

8.5.2 Report Setting

- a. Hospital : input the hospital name.

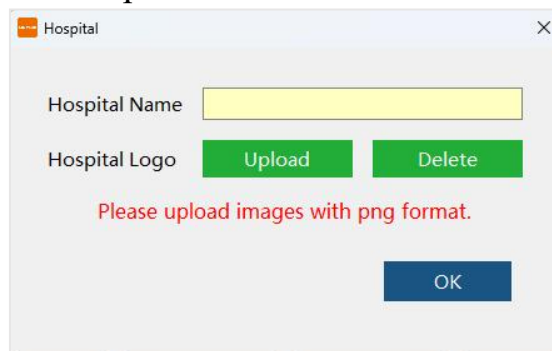

- b. Add Items: use this function to combine the test items from other devices to one report, after the change is complete, click ‘Save’ → ‘Exit’.
- c. Quality Control Parameters: Use this function to amend the quality control lot number, expiry date and target value. Make changes and after completion, click ‘Save’ and ‘Exit’.

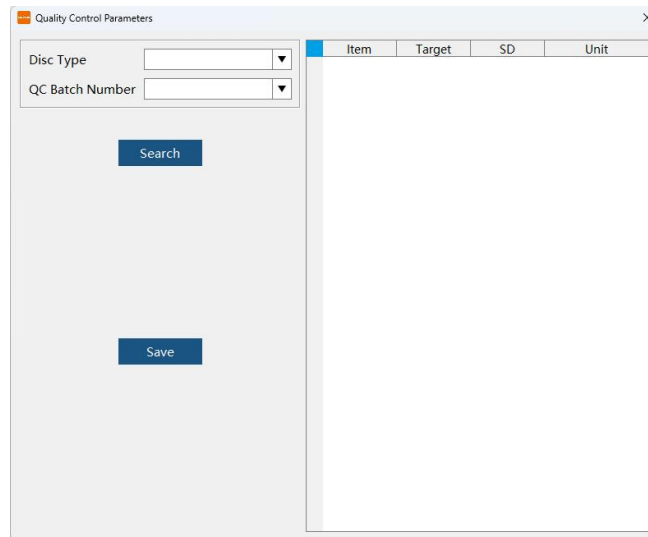

8.5.3 Test Info Setting

Modify the ‘Test Info’ in the main interface. The hospital can preset each item in the ‘Test Info Settings’ as needed and the setting items will be displayed in the report form. For example, the following settings interface.

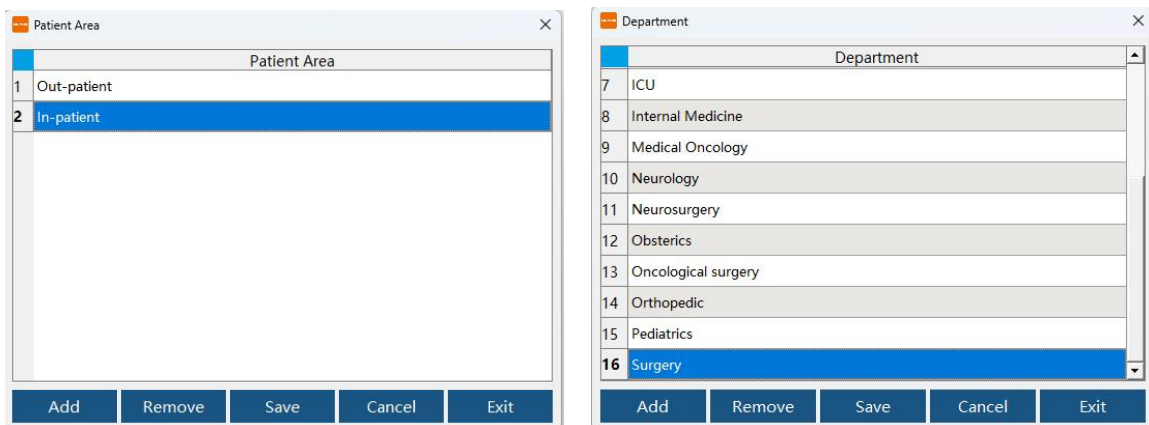

Note: ‘Inspection Note’ prompts abnormal samples (hemolysis / lipemia /jaundice) by default, hospitals can edit as per their needs in case of abnormal samples, the background of the report sheet is red, while it's yellow for normal samples.

Submitter	<input type="text"/>	135	<input type="checkbox"/>	Female		MNC1	2017-01-19 10:14
Submit Time	2017/01/05 21:16	136	<input type="checkbox"/>	Male		MNC1	2017-01-17 11:33
Operator	<input type="text"/>	137	<input type="checkbox"/>	Female		MNC1	2017-01-12 11:49
Reviewer	<input type="text"/>	138	<input type="checkbox"/>	Male	red	MNC1	2017-01-06 20:43
Diagnosis	<input type="text"/>	139	<input type="checkbox"/>	Male		MNC4	2017-01-05 22:37
Remark	Lipemia	140	<input checked="" type="checkbox"/>	Female	yellow	MNC3	2017-01-05 21:46
		141	<input type="checkbox"/>	Female		MNC2	2017-01-05 15:47
		142	<input type="checkbox"/>	Female		MNC1	2017-01-05 12:15
		143	<input type="checkbox"/>	Male		MNC1	2017-01-04 14:00
		144	<input type="checkbox"/>	Female		MNC2	2017-01-03 19:11

8.5.4 Advanced Setting

a. Change inspection Information

Select a patient and change the basic information from the inspection information area. Click ‘Save’ when the modification is complete.

Inspection Info		Patient info						
Analysis Date	2016/12/19	<input type="checkbox"/>	...	Male		MNC3	2016-12-19 11:13	11353
Patient Type	Out-patient	<input checked="" type="checkbox"/>	...	Male	36	MNC2	2016-12-19 10:03	11353
ID	MNC2	<input type="checkbox"/>	...	Female		MNC1	2016-12-19 01:49	11353
Name	mnchip							
Sex	Male							
Age	36 Years							
Department	Internal Medicine							
Bed NO.								
Sample Type	Serum							
Submitter								
Submit Time	2016/12/19 09:33							
Operator								
Reviewer								
Diagnosis								
Remark								

b. Display All

The ‘Analysis Date’ area of the Main screen usually only displays the data for the selected date. If you want to display all test results, you can use the ‘Display All’ function.

c. Combine

When the same patient has been tested using different discs, it is possible to combine the two test reports into one report and the merge function can be used. First, select the reports to be merged, click the ‘**Combine**’ function and the system will generate a new report. If there are the same test items in the combined test results, the average value of the same items is taken and the different items are displayed separately.

	Name	Sex	Age	ID	Time	Device Number
175	<input checked="" type="checkbox"/>	Female		MNC1	2016-06-20 07:55	11353
176	<input checked="" type="checkbox"/>	Female		MNC1	2016-06-20 04:40	11353
177	<input type="checkbox"/>	Female		MNC1	2016-06-19 07:37	11353

The screenshot shows the MNCHIP Medical Data Management Platform interface. On the left is the 'Inspection Info' form with fields for Analysis Date (2016/11/06), Patient Type (Out-patient), ID (MNC1), Name, Sex (Female), Age, Department (Internal Medicine), Bed No., Sample Type (Serum), Submitter, Submit Time (2016/06/20 07:25), Operator, Reviewer, Diagnosis, and Remark. A 'Save' button is at the bottom. On the right is the 'Patient info' section with a table of test results:

	Name	Sex	Age	ID	Time	Device Number
1	<input checked="" type="checkbox"/>	Female		MNC1	2016-06-20 07:55	11353
2	<input type="checkbox"/>	Female		MNC1	2016-06-20 07:55	11353
3	<input type="checkbox"/>	Female		MNC1	2016-06-20 04:40	11353

At the bottom of the Patient info section are buttons for 'Select all', 'Display All', 'Preview(V)', 'Print(F2)', 'Combine', and 'Delete'.

d. Delete:

Select one result and use the ‘**Delete**’ function to delete it.

Note: If the data is deleted by mistake, it can be recovered by resynchronizing the data from the analyzer..

e. Add Item:

Select a test result, click the ‘**Add Item**’. It will add a new line of items, double-click the blank space to: It will add a new line of items, double-click the blank space to add the corresponding content you require.

Note: The item you wish to add can't be same as an existing item

Patient info						Result			
	Name	Sex	Age	ID	Time	Item	Result	Ranges	Unit
1		Female		MNC1	2016-06-20 07:55				mg/dL
2		Female		MNC1	2016-06-20 04:40				mg/dL
5						TP	6.81	6 -- 8.3	g/dL
6						ALB	4.56	3.5 -- 5.5	g/dL
7						GLO	2.25	2 -- 4	g/dL
8						A/G	2.0	1.2 -- 2.4	
9						UREA	21.2	17.4 -- 49.2	mg/dL
10						CRE	0.13	0.28 -- 0.68	mg/dL
11						UA	1.77	1.5 -- 6	mg/dL
12						GLU	104	70 -- 110	mg/dL
13						TG	64	34 -- 150	mg/dL
14						CHOL	153	93 -- 201	mg/dL
15						HDL-C	52.7	44.6 -- 59.6	mg/dL
16						LDL-C	87	0 -- 120	mg/dL
17						LDL-C	0.0	0 -- 0	mg/dL

17	<input checked="" type="checkbox"/>	LDL-C	76	0 -- 120	mg/dL
*	<input checked="" type="checkbox"/>	LDL-C	0.0	0 -- 0	

Warning: The project already exist!

Yes

8.6 Capture Results using MMDMP



- Click 'Connect', the management platform will search all devices currently connected, if the connection is successful, the currently connected device will be displayed on the right side of the main menu.

Patient info						Current connection device CM1713001Z02	
	Name	Sex	Age	ID	Time	Device Number	Item
							Result

- Click 'Sync', select the time and click 'OK' to synchronize the data in the

device to MMDMP.

- Local connection: Synchronize data from the analyzer to the MMDMP software.
- Cloud connection: Synchronize data from the server to the MMDMP software.

Note: When opening the MMDMP software, the results from the day are automatically synchronized by default. If data synchronization is unsuccessful, find the report in the chemistry analyzer's Results Query and click Upload.

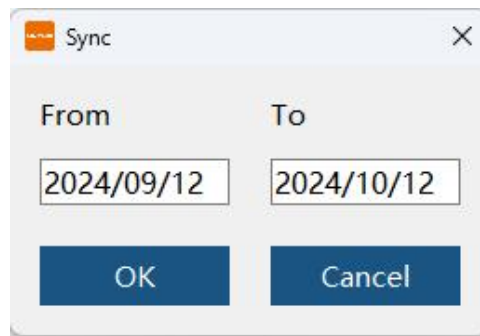

- c. Click '**Backup**' to backup or restore your data.
- '**Data Backup**': Backup data from the current management platform software to the specified path.
 - '**Data Recovery**': select the '**.mdb**' file you need to recover to recover the data.

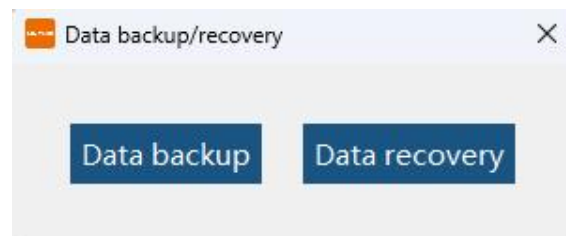

- d. Click '**Result**' to find the test records that meet the specified screening conditions. Enter any one or any combinations of test date range, name, medical record number, gender, age, device ID, project name and result range to screen report sheets.



- e. Click ‘Search’ to display the screened test records that meet the conditions.

Note: If you want to display all the reports in the MMDMP software, click ‘Show All’ in the ‘Main Interface’.

8.7 Report Printing

- a. **Report preview:** Select one patient result, the print preview will be shown.

Biochemical Inspection Report

Name: mnchip Sex: Male Age: 36 Years Sample Type: Serum
 ID: MNC2 Department: Internal Medicine Patient Type: Out-patient Bed No.:
 Clinical Diagnosis:

Item Name	Result	Indicator	Ranges	Unit
ALT	29		0-40	U/L
AST	35		0-40	U/L
TBIL	0.67		0-1	mg/dL
DBIL	0.36		0-0.4	mg/dL
IBIL	0.31		0-1	mg/dL
TP	6.71		6-8.3	g/dL
ALB	4.24		3.5-5.5	g/dL
GLO	2.47		2-4	g/dL
A/G	1.7		1.2-2.4	
UREA	33.2		17.4-49.2	mg/dL
CRE	0.75		0.28-0.96	mg/dL
UA	3.31		2.49-6.99	mg/dL
GLU	125	↑	70-110	mg/dL
TG	91		34-150	mg/dL
CHOL	114		93-201	mg/dL
HDL-C	27.0	↓	39.6-54.6	mg/dL
LDL-C	69		0-120	mg/dL

Submit Datetime: 2016-12-19 09:33 Analysis Datetime: 2016-12-19 10:03 Print Datetime: 2018-10-26 15:29
 Submitter: Operator: Reviewer:
 Remark: *The result is only responsible for this sample*

- b. **Report print:** Reports can be printed using the printer installed on a

Windows PC. Select the report to print, click ‘Print (F2)’.

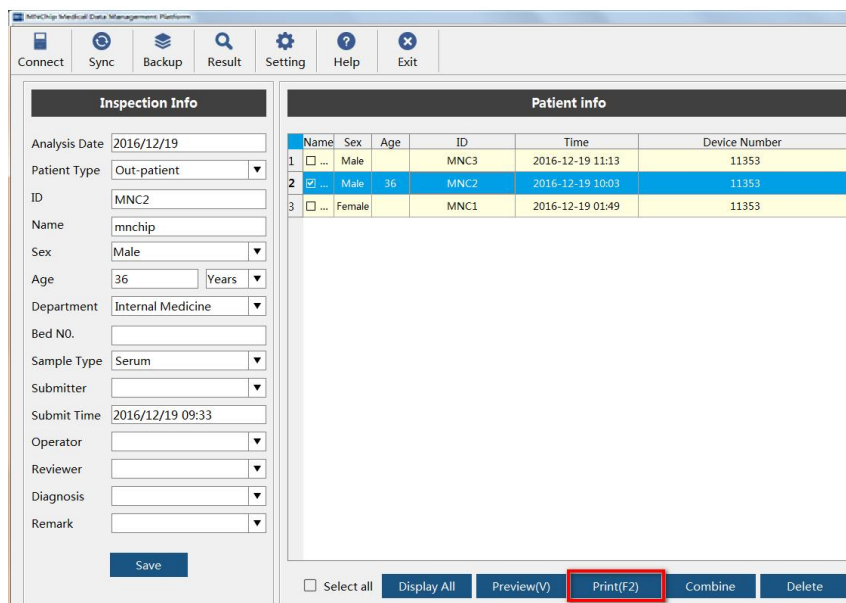

Select the corresponding printer to print.

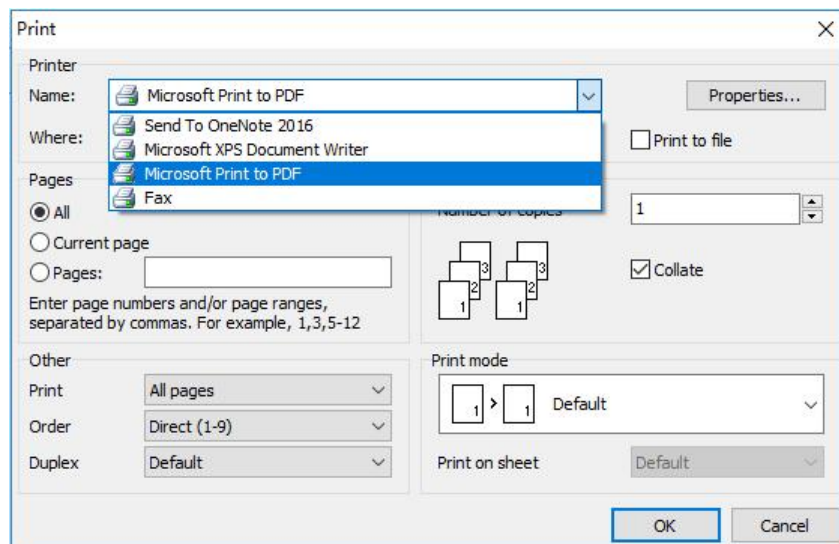

Note: If the PC is not connected to the corresponding printer, please install the printer firstly. Reporter layout can be designed using the printer's report setup function.

8.8 Troubleshooting

If the test results cannot be synchronized with MMDMP, try the following solutions:

- a. Update the analyzer software version

Turn on the analyzer, click ‘Setting’ → ‘Network’ to connect to WI-FI. After connecting to the Internet successfully, return to ‘Setting’ →

- ‘**Analyzer**’ to update the analyzer software to the latest version.
- b. If it is ‘**local transmission**’, please ensure that the data cable is connected correctly, then restart the analyzer and management platform software; if it is ‘**cloud transmission**’, please make sure that the analyzer and PC with the software installed are connected to the Internet.
- c. Uninstall the MMDMP software and re-install the latest version

Locate the uninstallation software in the installation documentation, click *unins000.exe*, start the uninstall feature and click ‘**Yes**’. The software will be removed from the computer. Install the software again as described in **8.2**.

