

**MNCHIP**

# Pointcare V3

Automatic Chemistry Analyzer

## Operator's Manual

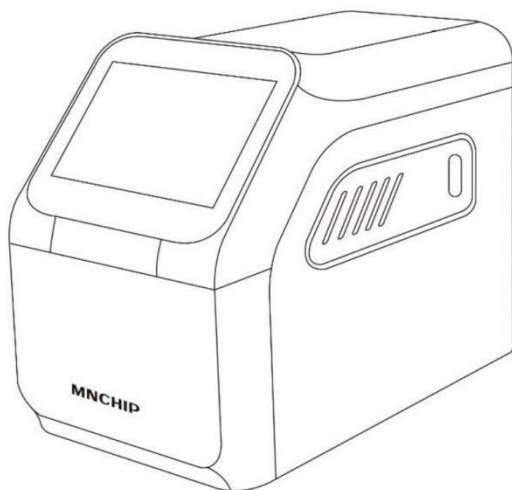

Please read the Operator's Manual carefully before use  
For veterinary use only

CE

**Tianjin MNCHIP Technologies Co., Ltd.**

**Add.:** 1-4F, Area, No.122 Dongting Rd, Development Zone, 300457 Tianjin P.R. China

**SRN:** CN-MF-000029863

**Service email:** [service@mnchip.com](mailto:service@mnchip.com)

Learn more about MNCHIP, other products can log in: <http://www.mnchip.com>

**Umedwings Netherlands B.V.**

**Add.:** Treubstraat 1,2288EG,Rijswijk, the Netherlands

**SRN:** NL-AR-000000444

**Email:** [ar@umedwings.eu](mailto:ar@umedwings.eu)

Issue Date:2025.03.06

Version: 1.4

©2025 Tianjin MNCHIP Technologies Co., Ltd.

# Table of Contents

---

<i>Statements</i> .....	1
<i>Safety Precautions</i> .....	3
<b>Section 1 General Information</b> .....	<b>6</b>
1.1 Intended Use .....	6
1.2 Introduction .....	6
1.3 Analyzer Specifications and Environmental Requirements .....	7
1.4 Technical Support .....	8
1.5 Symbols Used in Labeling .....	8
1.6 Transport and Storage .....	9
1.6.1 Transport .....	9
1.6.2 Storage .....	10
<b>Section 2 Installation</b> .....	<b>11</b>
2.1 Product Inspection and Damage Check .....	11
2.2 Unpacking .....	11
2.2.1 Unpacking the Analyzer .....	11
2.2.2 Functional Description of the Analyzer .....	11
2.2.3 Important Steps After Receiving the Analyzer .....	13
2.3 Installation .....	13
2.3.1 Setup Instructions .....	13
2.3.2 Power Connection .....	13
2.4 Setup .....	13
<b>Section 3 Sample Analysis and Result</b> .....	<b>16</b>
3.1 System Description .....	16
3.2 Sample Requirements .....	16
3.3 Preparing the Reagent Disc .....	17
3.3.1 Disc Structure and Function .....	17
3.3.2 Disc Structure and Function .....	18
3.4 Sample Analysis .....	20
3.5 Canceling Analysis .....	23
3.6 Report .....	24
3.6.1 Report Information .....	24
3.6.2 Interpretation of Results .....	25
3.7 Recalling Results .....	26
<b>Section 4 Calibration and Quality Control</b> .....	<b>28</b>
4.1 Calibration .....	28

4.2 Quality Control .....	28
4.2.1 Quality Control During Analysis .....	28
4.2.2 Quality Control .....	29
4.3 Control Analysis .....	30
4.3.1 Control Analysis .....	30
4.3.2 Recalling Control Results .....	32
<b>Section 5 Configuring the Analyzer .....</b>	<b>35</b>
5.1 Analyzer Information .....	35
5.2 Network Connection .....	36
5.3 Changing Date and Time .....	37
5.4 Report Layout .....	37
5.5 Setting Sound .....	42
5.6 Setting Language .....	42
5.7 Sample Type .....	43
5.8 Setting Baud Rate .....	43
5.9 Operation Settings .....	44
5.10 Setting LIS Function .....	44
5.11 Permission Management .....	45
5.12 LAN Settings .....	50
5.13 Other Settings .....	51
<b>Section 6 Troubleshooting .....</b>	<b>52</b>
6.1 Electrostatic Discharge .....	52
6.2 Error Codes for Analyzer and Troubleshooting .....	52
6.3 Error Codes for Reagent Disc and Troubleshooting .....	53
<b>Section 7 Maintenance .....</b>	<b>54</b>
7.1 Cleaning the Analyzer .....	54
7.2 Cleaning the Air Filter .....	54
7.3 Updating the Analyzer Software .....	55
7.3.1 Automatic Update .....	55
7.3.2 Manual Update .....	56
7.4 Installing Thermal Printer Paper .....	58
<b>Section 8 MNCHIP Medical Data Management Platform .....</b>	<b>59</b>
8.1 MMDMP .....	59
8.2 Cleaning the Analyzer .....	59
8.3 Login .....	61
8.3.1 Local login .....	61
8.3.2 Cloud login .....	61
8.4 ‘Main Screen’ Description .....	62

8.4.1 Inspection Info .....	63
8.4.2 Patient Info .....	66
8.4.3 Result .....	66
8.5 Setting .....	66
8.5.1 Basic Setting .....	67
8.5.2 Report Settings .....	68
8.5.3 Test Info Setting .....	69
8.6 Switching Data Transfer Methods .....	70
8.7 Acquisition, Backup, and Querying of Patient Data .....	71
8.8 Report Printing .....	72
8.9 Troubleshooting .....	73

## *Statements*

Thank you for purchasing the Pointcare V3 Chemistry Analyzer. This manual is designed for operators who have completed the training course provided by MNCHIP or its authorized dealers. Please read and understand this Operator's Manual carefully before using the system.

The Pointcare V3 Chemistry Analyzer is an IVD medical device suitable for use in medical testing institutions. The symbols used in labeling comply with ISO 18113-3 standards.

### **Warranty Information:**

MNCHIP guarantees that the device is free from design, material, and manufacturing defects within the specified period, provided that you have submitted the product installation information to us.

### **To Obtain Warranty Service:**

- Contact the distributor from whom you purchased this product.
- If your issue is not resolved satisfactorily, reach out to MNCHIP Customer Service directly.
- For specific contracts with MNCHIP, contact Customer Service directly.

### **Limitations of Warranty:**

MNCHIP's obligation under this warranty is limited to repairing or replacing any parts returned by the purchaser at MNCHIP's discretion.

MNCHIP will not be responsible for any incidental, special, or consequential losses, damages, or expenses arising directly or indirectly from the use of this product.

**This warranty shall become null and void if:**

1. The equipment has been misused, neglected, abused, damaged by accident, or affected by force majeure.
2. The equipment has been modified or repaired by anyone other than an authorized MNCHIP Service Representative.
3. The original MNCHIP serial number label or product identification markings have been altered or removed.
4. Any non-standard accessories have been attached or modifications made to the equipment.

Thank you for choosing MNCHIP products.

## *Safety Precautions*

This product conforms to European Directive 98/79/EC. To use the analyzer safely and effectively, please observe the following precautions. Using the system in a manner not specified by the manufacturer may impair its safety features.

### ***1. Safety Information***

The Pointcare V3 Chemistry Analyzer includes a built-in centrifuge that complies with EN/IEC 61010-2-020. Operators are prohibited from replacing the centrifuge, rotor, or related accessories without proper authorization. For installation, operation, and maintenance of the centrifuge, follow the guidelines outlined in this manual.

The Pointcare V3 Chemistry Analyzer has passed transportation tests in accordance with ASTM D4169:2016 DC13.

### ***2. Wi-Fi Compliance***

The analyzer complies with EN 300 328 V2.2.2:2019, EN 62311:2008, EN 301 489-1 V2.2.3:2019, and EN 301 489-17 V3.2.4:2020.

### ***3. EMC Information***

This product meets emission and immunity requirements as per EN/IEC 61326-2-6 and EN/IEC 61326-1 standards. It has been designed to CISPR 11 Class A specifications but may cause radio interference in certain environments; mitigation measures may be necessary.

It is the manufacturer's responsibility to provide electromagnetic compatibility information to users, while users must ensure a compatible environment for optimal device performance.

Evaluate the electromagnetic environment before operating this equipment and avoid using it near strong electromagnetic radiation sources (e.g., unshielded RF sources).

### ***4. Prevention of System Failures and Flammability***

Ensure correct installation according to the conditions specified in this manual.

### ***5. Preventing Electric Shocks***

Do not remove covers secured by screws (e.g., rear cover or side covers) unless authorized by MNCHIP personnel. If liquid spills occur inside the system, contact your service provider or Dealer's Technical Support immediately; careless handling of liquids can result in electric shock.

## ***6. Preventing Infection***

Improper handling of samples poses an infection risk. Always wear gloves when handling samples; do not touch them with bare hands. If samples come into contact with skin, wash thoroughly and consult a physician if necessary. Clean any contaminants from the system promptly.

Please refer to occupational safety and biosafety guidelines in your country or region for more information:

- Laboratory Biosafety Manual (4th Edition), World Health Organization (WHO, 2020).
- Directive 2000/54/EC on the protection of workers from risks related to biological agents (applicable to EU member states).
- Standards and guidelines issued by your country's occupational safety and health authority (e.g., OSHA in the United States or equivalent agencies in other countries).

### ***WARNING:***

***Operators must comply with national, regional, or local biosafety regulations, which may impose additional requirements beyond the above standards to ensure greater safety and compliance.***

## ***7. Handling Reagents***

Reagent beads may contain hazardous substances; avoid ingestion or contact with skin or inhalation when handling them-especially during cleanup after an incident involving broken reagent discs.

## ***8. Treating Waste***

Used reagent discs contain human blood samples; follow laboratory safety practices for their disposal according to local government guidelines.

For reference:

- Directive (EU) 2018/851 on waste management.
- CLSI document GP05 'Clinical and Laboratory Standards' available at <http://www.clsi.org>.

### ***9. WEEE Compliance***

The Pointcare V3 Chemistry Analyzer complies with Directive 2012/19/EU on waste electrical and electronic equipment (WEEE). Disposal arrangements should be made through your distributor or MNCHIP at end-of-life.

### ***10. RoHS Compliance***

Analyze components for harmful substances such as Pb, Cd, Hg, Cr(VI), PBBs, PBDEs, DEHP, BBP, DBP, and DIBP content to ensure compliance with RoHS Directive 2011/65/EU (RoHS 2.0) and its amendments (Directive EU 2015/863).

# Section 1 General Information

## 1.1 Intended Use

The Pointcare V3 Chemical Analyzer is designed for the quantitative in vitro determination of clinical chemical analytes in lithium heparinized whole blood, heparinized plasma, or serum. It is intended for use in medical testing institutions.

## 1.2 Introduction

The MNCHIP Pointcare V3 Analyzer utilizes microfluidic technology and consists of a compact analysis device paired with a disposable reagent disc that contains integrated reagents.

### Key components and features include:

- Color LCD Screen: For user interaction.
- Variable Speed Motor: Rotates the reagent disc to facilitate sample flow.
- Photometer: Measures analyte concentrations.
- Main Control Circuit Board: Manages testing and analytical functions.
- Built-in Wireless Communication Module: Enables software upgrades and remote technical support.
- QR Code Scanner: Located on the side of the analyzer; used to scan information from the reagent and patient details.

The reagent disc contains a dilution box (depending on the disc type) at its center and dry reagent beads in cuvettes around the edge. All blood separation and sample dilution occur within the disc.

### To perform an analysis:

1. Collect a blood sample (lithium heparinized whole blood, plasma, or serum).
2. Place the sample (and diluent if required) into the reagent disc.
3. Place the disc into the slot of the front drawer of the analyzer.
4. Enter patient information.

Once analysis is complete, results can be viewed on the touch screen or printed directly by connecting a printer.

Connectivity options include an Ethernet port, USB port, and wireless network capabilities, allowing data transfer to external printers, computers, memory sticks, data clouds, or laboratory information systems/electronic medical records (LIS/EMR).

Detection time varies based on sample type and reagent combination but typically ranges from 7 to 12 minutes.

*Note: This manual includes screenshots for reference only; actual screens may vary from those displayed here.*

### 1.3 Analyzer Specifications and Environmental Requirements

The following outlines the key specifications of the analyzer and the requirements for its operating environment:

- Analyzer Specifications
  - Dimensions: 210 mm (Length) × 125 mm (Width) × 175 mm (Height)
  - Weight: Approximately 3 kg
  - Operation Mode: Continuous operation
  - Light Source: Xenon lamp
  - Reaction Volume: 100 µL
- Environmental Requirements
  - Operating Temperature: The analyzer is designed for indoor use and functions optimally within a temperature range of 10°C to 30°C (50°F to 86°F).
  - Atmospheric Pressure: The device can operate at atmospheric pressures ranging from 86.0 kPa to 106.0 kPa, equivalent to altitudes up to 2000 meters (6562 feet).
  - Humidity: The recommended ambient humidity range is 40% to 85%.
- Power Requirements
  - Power Consumption: 120 VA

- **Input Voltage:** The analyzer supports a wide range of main supply voltages, from 100 to 240 volts AC, with a frequency of 50–60 Hz.

This specification ensures the analyzer operates reliably under the stated environmental conditions and power requirements. For optimal performance and longevity, it is important to adhere to these guidelines.









### 1.4 Technical Support









For questions regarding the operation of the Pointcare V3 Chemistry Analyzer, please contact the Dealer’s Technical Support team.

- **Email:** [service@mnchip.com](mailto:service@mnchip.com)

### 1.5 Symbols Used in Labeling

The following symbols are found on the analyzer or labelling:

Item	Description
	<b>Biological risks</b>
	<b>USB connection</b>
	<b>CE MARK</b>
	<b>Direct current</b>
	<b>Manufacturer</b>
	<b>Authorized representative in the European Community</b>
	<b>Unique device identifier</b>
	<b>In vitro diagnostic medical device</b>

	<b>Please refer to the user manual or electronic user manual</b>
	<b>Caution. Refer to any accompanying documents</b>
	<b>Electrical and electronic equipment, Do not discard at will, please recycle</b>
	<b>Fragile, handle with care</b>
	<b>Keep dry</b>
	<b>This is the correct upright position of the distribution packages for transport and/or storage</b>
	<b>Distribution packages shall not be rolled or turned over</b>
	<b>Up to 6 identical transport packages can be stacked on the bottom package</b>

## 1.6 Transport and Storage

### 1.6.1 Transport

The Pointcare V3 Chemistry Analyzer has been tested and complies with ASTM D4169:2016 DC13 standards.

- **Transport Conditions:**
  - Ensure the product is transported in good condition, covered with canvas if necessary to prevent moisture and rain exposure.
  - Goods should be arranged orderly and compactly on the transport vehicle to prevent damage from shaking.
- **Safety Precautions:**
  - Do not transport with flammable, explosive, or corrosive materials in the same vehicle.

- Protect product components from rain, snow, liquid exposure, or mechanical damage during transportation.

## 1.6.2 Storage

- Storage Environment:
  - Temperature: 0°C to +40°C.
  - Humidity: Not exceeding 85%.
- Storage Recommendations:
  - Products should be kept in their original packaging to maintain protective measures.
  - The storage area must be protected against moisture, dust, shock, and corrosion.
  - It is recommended to install air conditioning and adequate lighting in the storage facility.

## Section 2 Installation

### 2.1 Product Inspection and Damage Check

Before packaging and transportation, the analyzers undergo strict inspections by our professional staff. Products are transported to the installation site via a designated transportation company.

Upon receiving the analyzer, please carefully inspect the outer package for the following potential damages before unpacking:

- Apparent deformation
- Signs of immersion
- Impact marks
- Evidence of being opened

If any damage is found, do not open the product. Immediately inform our after-sales service personnel or local dealers.

If no damage is detected, you may proceed with the installation steps outlined below.

### 2.2 Unpacking

#### 2.2.1 Unpacking the Analyzer

- Carefully remove the Pointcare V3 Chemistry Analyzer from the shipping carton.
- Place the analyzer on a level surface that is clean and free of hair, dust, and other contaminants.
- Avoid positioning the analyzer in direct sunlight or near any heat sources.

#### 2.2.2 Functional Description of the Analyzer

The following figures illustrate the functional description of each part of the analyzer. Each component is labeled for clarity, allowing you to understand its purpose and operation.

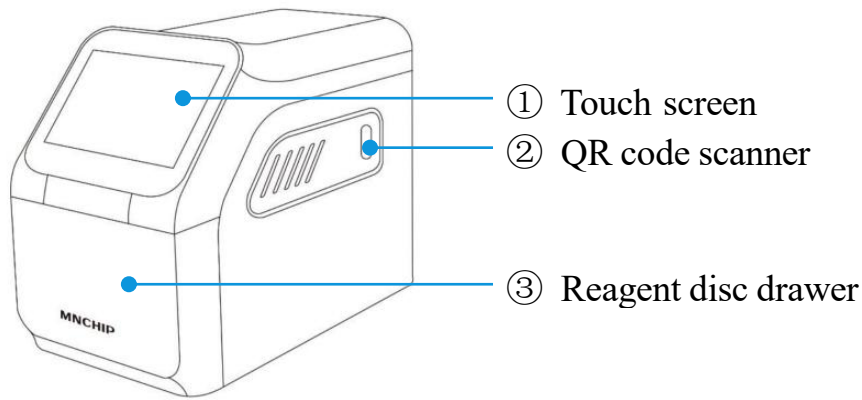

The front of the analyser

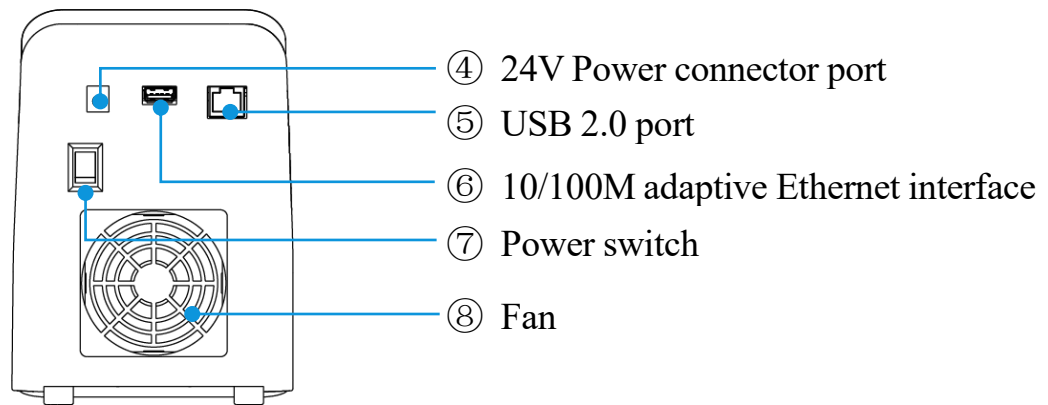

The rear of the analyzer

NO.	Item	Function
1	Touch screen	For human-computer interaction
2	QR code scanner	Scan the QR code of the reagent
3	Reagent disc drawer	Test area, place reagent disc
4	24V Power connector port	Power connector port
5	USB 2.0 port	Data transfer, computer connection, printer connection
6	10/100M adaptive Ethernet interface	Access the network by connecting network cables
7	Power switch	Turn on/Turn off the device
8	Fan	Ventilation and heat dissipation during operation

### 2.2.3 Important Steps After Receiving the Analyzer

- **Component Verification:** Check the components received with the Pointcare V3 Chemistry Analyzer against the Packing List to ensure that all items required for setup are included.

## 2.3 Installation

### 2.3.1 Setup Instructions

Set up the analyzer on a surface according to the following guidelines:

- Ensure it is on a level surface with no obstructions blocking the reagent disc drawer.
- Place it in an area free of vibrations and sudden jolts.
- Keep the surface free of hair, dust, and other contaminants.
- Maintain an ambient operating temperature of 10–30 °C (50–86 °F).
- Position it away from direct sunlight and any other potential heat sources.
- Ensure there is at least 30 cm (12 inches) of space from any wall to provide adequate ventilation and access to power connections and USB ports.

### 2.3.2 Power Connection

Plug the power cable into the analyzer. Connect the detachable power supply cord to the power adapter, then plug it into a grounded electrical outlet.

#### **Caution:**

- DO NOT use improperly rated power cords or adapters.
- To prevent power surges or drain, DO NOT plug the analyzer into the same circuit as a centrifuge or any other high-current device.
- MNCHIP recommends using a surge protector similar to those used for computers.

## 2.4 Setup

Plug the power cable into the Analyzer. Connect the detachable power supply cord to

the power adapter, then plug it into a grounded electrical outlet.

*Note: This manual includes screenshots for reference only; actual screens may vary from those displayed here.*

**Caution:**

- To prevent power surges or drain, DO NOT plug the analyzer into the same circuit as a centrifuge or any other high-current device.

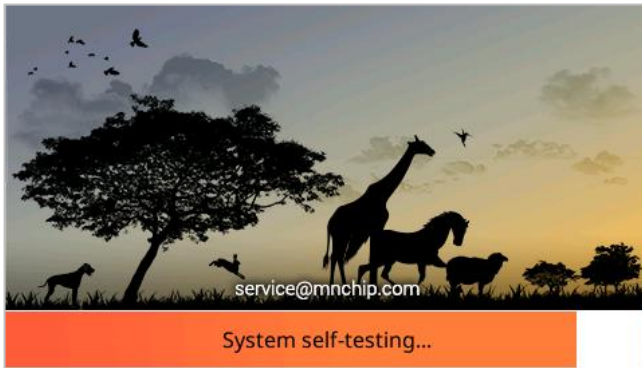

1. Press the Power button to turn on the analyzer.
2. During the self-test and warming period, the display will show the image on the left.

*Note: The analyzer may require additional time for the heaters to reach operating temperature in low ambient temperatures.*

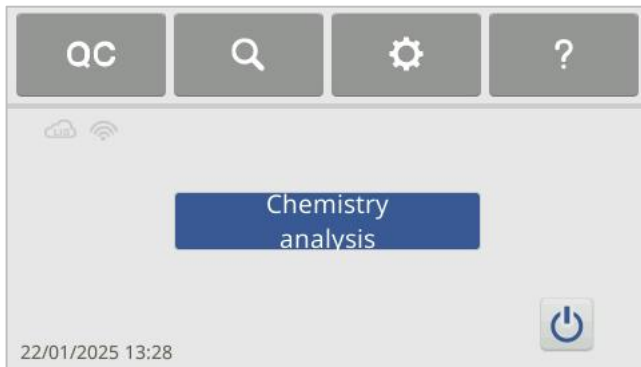

3. After successfully completing the self-test and reaching the operating temperature, the analyzer is ready to run the first reagent disc. The display will show the image on the left.

4. Check the analyzer's date and time to ensure they are correct. If adjustments are needed, please refer to **Section 5.2**, 'Changing Date and Time' for detailed instructions.

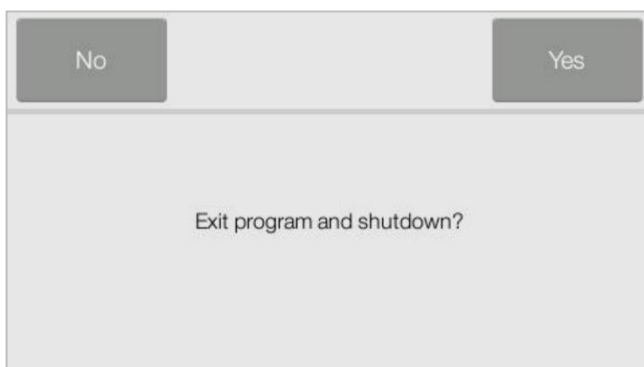

5. To shutdown the analyzer, press the '⏻' on the home page, then turn off the power button.

7. The analyzer can be connected to an external printer for printing patient and control results. Please ensure the printer is compatible and follow the manufacturer's instructions for connection.

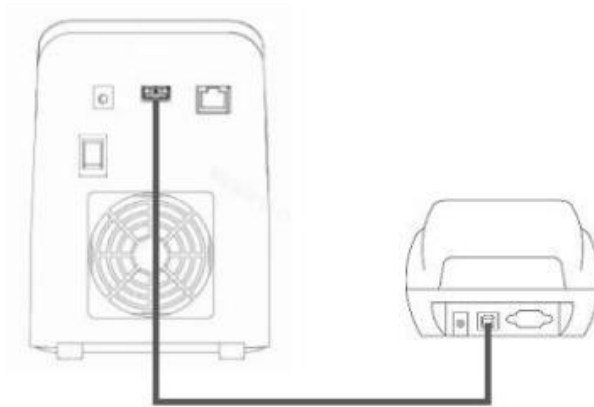

8. The reference ranges are preset in the analyzer. You can modify these values using the 'Ranges' feature, which is explained in **Section 5.4**.

## Section 3 Sample Analysis and Result

### 3.1 System Description

1. The Pointcare chemistry system consists of a portable analyzer and disposable single-use reagent discs. Each reagent disc contains all the necessary reagents to perform a panel of tests on a single sample. Familiarize yourself with the system before running samples.
2. The Pointcare analyzer utilizes centrifugal and capillary forces to process heparinized whole blood samples, distributing diluted plasma into the reaction chambers (cuvettes) in the reagent disc. Serum and heparinized plasma samples are processed similarly. The analyzer optically measures chemical reactions and calculates analyte concentrations based on these measurements and encoded calibration data found on the QR code located on the reagent disc pouch.
3. Results are stored in memory and can be printed using an external thermal printer or downloaded to a personal computer for use with the MNCHIP Medical Data Management Platform (MMDMP). The touch screen display provides intuitive communication with the analyzer, showing procedural instructions, indicating the status of the analyzer, and presenting any error messages. For details on error messages, refer to **Section 8**.

### 3.2 Sample Requirements

- a. The Pointcare V3 Chemistry Analyzer only accepts lithium heparinized whole blood, plasma, or serum samples.

*Note: When collecting samples in lithium heparin collection tubes, fill the tube at least halfway to prevent excessive concentration of the anticoagulant in the sample.*

*EDTA contamination severely affects results, especially for calcium (Ca) and potassium (K<sup>+</sup>). The use of a sodium heparin tube will falsely elevate sodium (Na<sup>+</sup>) results.*

- b. For information on applicable sample types for each disk, please refer to the corresponding kit Instructions for Use (IFU).
- c. A sample size of 90-120 µl is required.

- d. Whole blood must be analyzed within 60 minutes of collection or separated into plasma or serum.

*Note: If not analyzed immediately, plasma or serum can be stored at room temperature for no longer than 5 hours after centrifugation. For storage beyond 5 hours, refrigerate the sample in a capped tube at 2–8°C (36–46°F) for no more than 48 hours, or store at –10°C for up to 5 weeks in a freezer without a self-defrost cycle. Under these conditions, most analyte concentrations remain clinically stable.*

**Caution:**

- To prevent hemolysis, do not refrigerate or shake whole blood.
- e. For accurate interpretation of glucose results, patients should fast for at least 12 hours before sample collection.

### 3.3 Preparing the Reagent Disc

#### 3.3.1 Disc Structure and Function

The reagent disc consists multiple cuvettes located around its periphery, some of which contain test-specific lyophilized reagent beads necessary for performing one or more tests on a single sample:

- A specially designed cuvette detects whether the sample volume is sufficient.
- A specially designed cuvette detects whether the diluent volume is sufficient.
- A cuvette verifies that a sufficient diluted sample was delivered to the reaction cuvettes; an empty cuvette captures excess fluids.
- Multiple cuvettes contain test-specific lyophilized reagent beads.
- The sample port, marked by a circle on the disc's upper surface, provides access to the sample chamber.
- A sample diluent is sealed in a container inside the disc. At the beginning of the reaction cycle, this container is opened to release the diluent. The reagent disc used for testing blood ammonia does not have a built-in diluent container.

The structure of the reagent disc is shown below:

Disc with diluent container

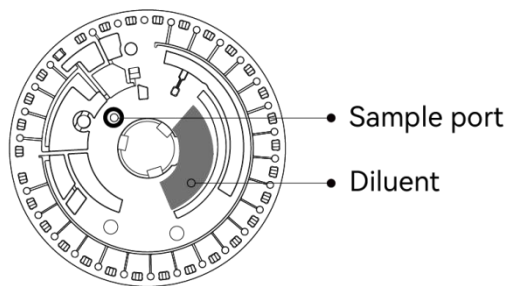

The analyzer separates a lithium heparinized whole blood sample by centrifugation within the disc. Plasma and serum samples remain unaffected. Precisely measured quantities of both sample and diluent are delivered to the mixing chamber. Centrifugal and capillary forces then transport the diluted sample to the cuvettes, where it dissolves the reagent beads and initiates the chemical reactions. The reaction products in the cuvettes are subsequently measured photometrically

### 3.3.2 Disc Structure and Function

Open the disc pouch at the notch located on the top right edge of the package. Carefully remove the reagent disc and place it flat on a table.

#### **Disc with diluent container:**

##### a. Opening the Diluent Container

- Position the reagent disc so that the side with the aluminum strip faces you.
- Tear off the aluminum strip in the direction of its extension to open the diluent container, allowing the diluent to be released into the diluent chamber of the reagent disc.
- Place the reagent disc face up on a flat surface.

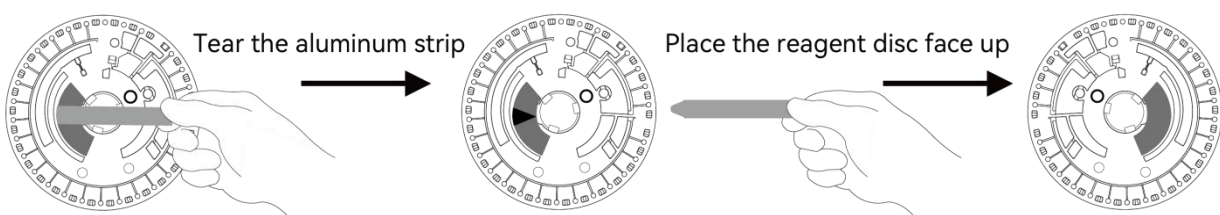

## b. Dispensing Sample

- Use a 100  $\mu\text{L}$  volume pipette and attach a clean pipette tip to its end.
- Hold the pipette and press down on the top button using your thumb until it reaches its stop position, then hold it there.
- Immerse the pipette tip below the sample level and slowly release the button to draw up the sample.
- Remove the pipette from the sample, ensuring there are no air bubbles in the tip.

**Note:** *Whole blood samples obtained by venipuncture must be homogeneous before transferring a sample to the reagent disc. Gently invert the collection tube several times just prior to sample transfer. Do not shake the collection tube; shaking may cause hemolysis.*

*When the sample is serum or plasma, be careful not to draw blood cells into the pipette tip.*

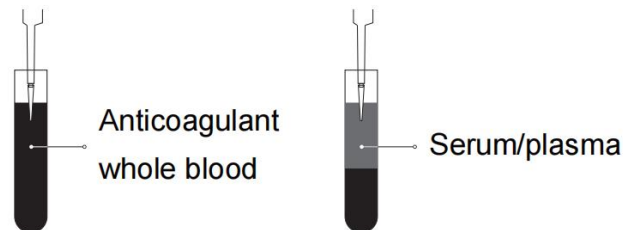

## c. Adding Sample

- Ensure the pipette tip is vertically inserted into the sample well of the disc. Then, tilt the pipette at a 45° angle. Press the top button slowly until all of the sample is dispensed into the disc.
- After adding the sample, carefully discard the pipette tip into a designated biohazard container to ensure safe disposal.

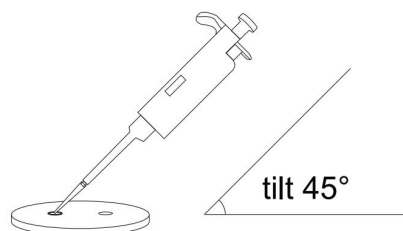

### **Note:** *Disc Storage and Handling*

- Storage:** Store each reagent disc as described on its label to maintain the stability of the reagents until the expiration date printed on the disc's foil pouch. The analyzer will automatically reject any expired disc.

- b. **Temperature:** Discs can be used directly from the refrigerator (stored at 2 - 8 °C / 36 - 46 °F) without warming.
- c. **Sunlight Exposure:** Avoid exposing discs, whether inside or outside their foil pouches, to direct sunlight or temperatures exceeding 32°C (90°F).
- d. **Inspection:** Inspect the unopened foil pouch for tears and punctures. A torn or damaged pouch can allow moisture to reach the disc, reducing reagent performance.
- e. **Usage Timeframe:** Once opened, discs must be used within 20 minutes. Do not return an opened disc to the refrigerator for later use.
- f. **Cleanliness:** Keep discs clean by handling them only by their edges to avoid smudges on optical surfaces. Use a lint-free tissue to remove any spilled blood from disc surfaces.
- g. **Glove Usage:** Wear powder-free gloves while handling reagent discs or operating the analyzer, as powder can disrupt the analyzer ' s optical components.
- h. **Handling After Sample Introduction:** Hold reagent discs flat after introducing a sample or control to avoid spillage.
- i. **Fragility Warning:** Discs are fragile; always handle with care. Inspect every reagent disc for damage before use, and never use a damaged disc.

### 3.4 Sample Analysis

This section includes detailed, step-by-step instructions for performing analyses using the analyzer.

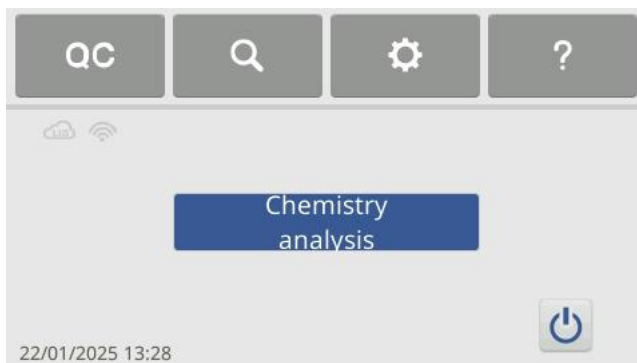

1. After passing the self-testing, the analyser will display the main screen (operating interface) as the image on the left shows.
2. Press '**Chemistry Analyze**' to start the analysis.

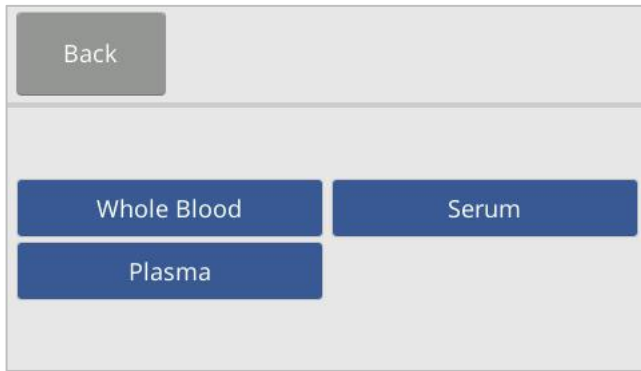

3. Select **‘Whole Blood’**, **‘Serum’**, or **‘Plasma’** depending on the sample type. the screen for scanning the QR code is the displayed.

4. Scan the QR code on the label of the foil pouch. The QR code contains important disc information, including: Disc identification code, Lot number, Expiration date.

*Note: Before scanning, ensure that the QR code label is flat and that there is sufficient light in the surrounding environment.*

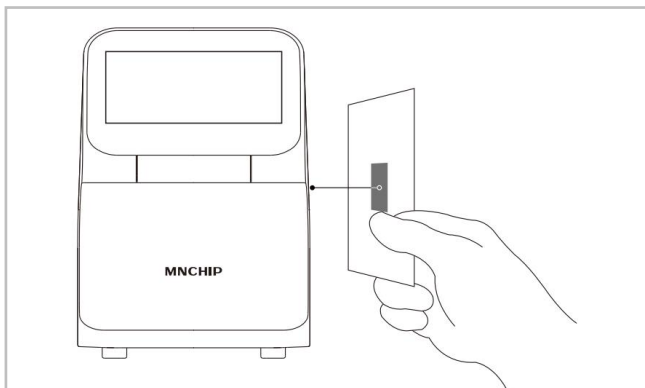

a. Position the QR code in front of the QR scanner located on the right side of the Analyzer. Hold it steady to scan the QR code.

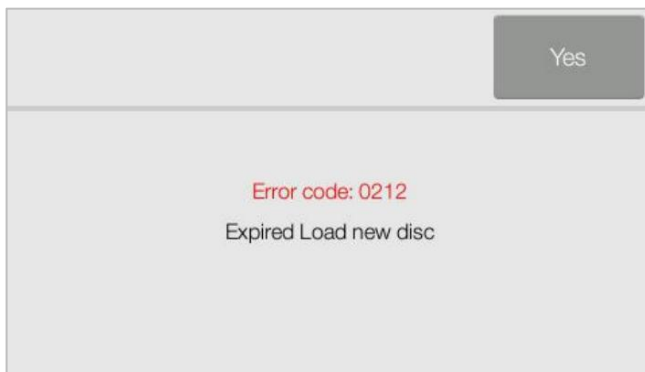

b. Once the scan is complete, a prompt displaying the disc type name will appear on the screen. If the disc is expired, a notification will be shown. Please rescan with a new disc.

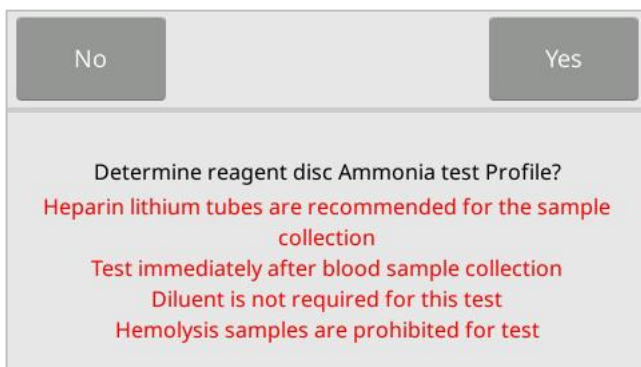

c. Press **‘Yes’** to confirm that this is the correct disc type for running the patient sample.

**OR**

d. Press **‘No’** to cancel the current disc information and scan a new disc.



e. Press the **‘Page Up / Page Down’** to select the patient’s species, and the disc drawer will open. Load the disc.

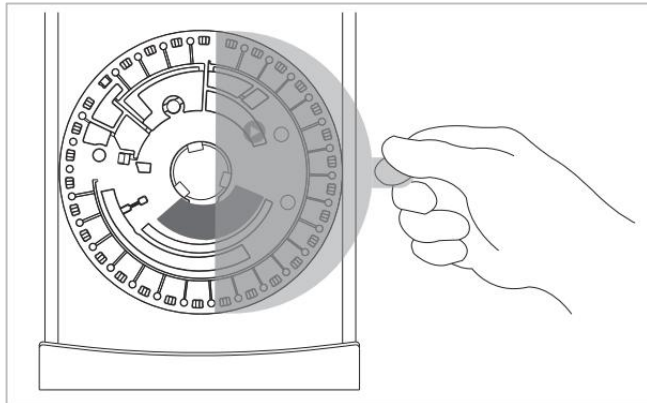

5. According to the procedure outlined in **Section 3.3**, add the patient sample to the disc. Press **‘Yes’** to open the drawer, then place the disc in the recessed area of the drawer (if the disc has a blue film, please remove it before placing it in the drawer). Close the drawer to complete the process.

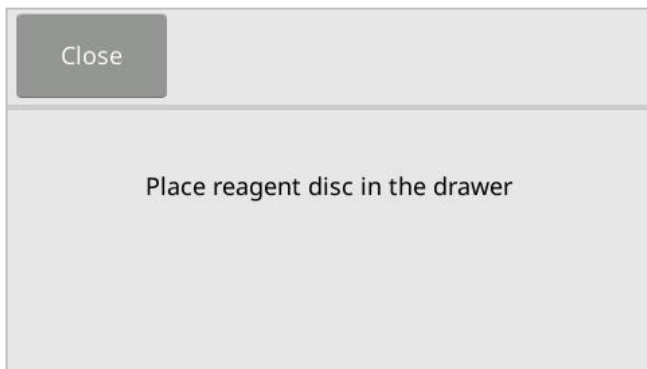

6. Press **‘Close’** and the drawer will close automatically.

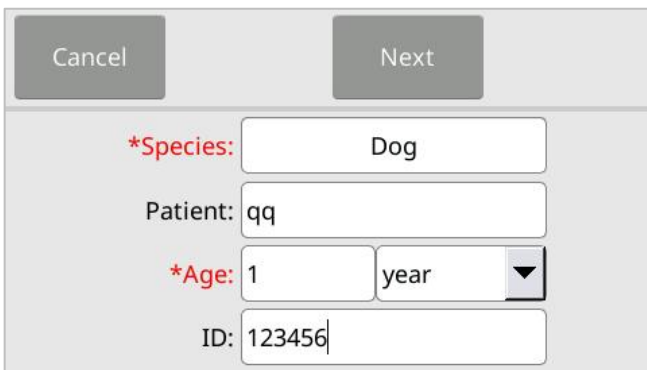

7. Once the patient species is selected, the patient information input screen will appear. Use the keyboard to enter the **patient's name, owner's name, patient ID, and age**. Select the **patient's gender**, then press **‘Next’**.

*Note: Required items are marked with an asterisk (\*). After entering all required information, click ‘Next’.*

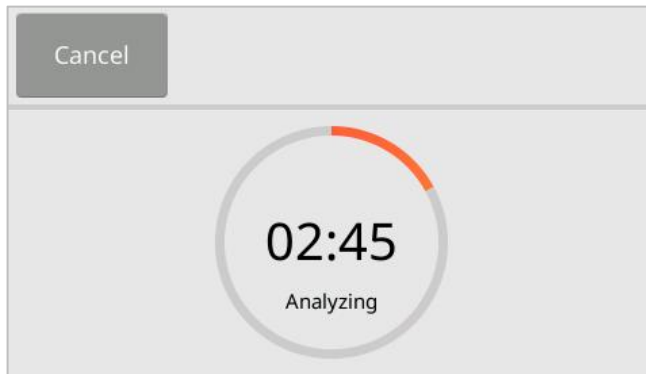

8. After entering the patient's information, the analyzer will show a progress bar along with a countdown timer for the analysis.

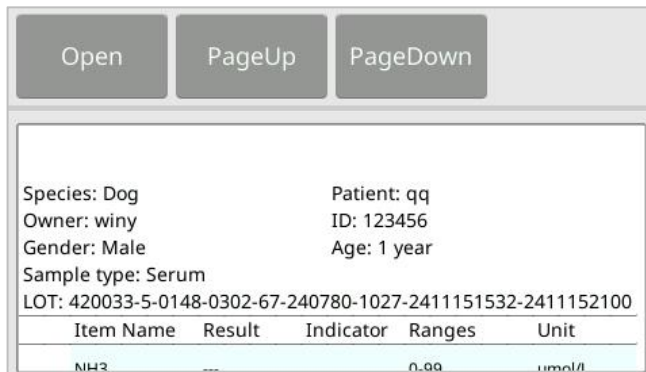

9. Once the analysis is complete, the analyzer will store the results in memory and display them on the screen, as illustrated in the figure. You can print the test results using the builtin thermal printer or through the MNCHIP management platform software.

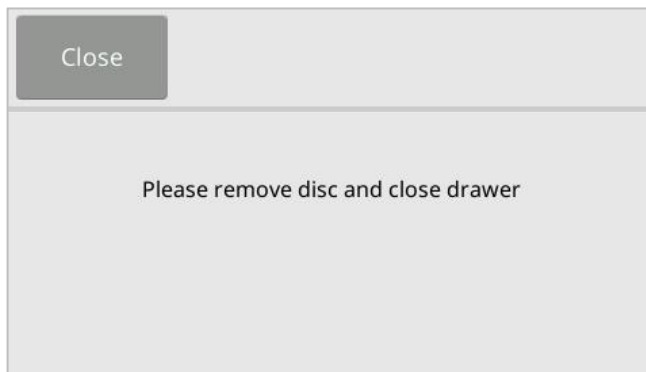

10. Press **'Open'** to access the drawer and remove the disc. Afterward, press **'Close'** to shut the drawer and return to the main screen. The analyzer is now ready for another test.

### 3.5 Canceling Analysis

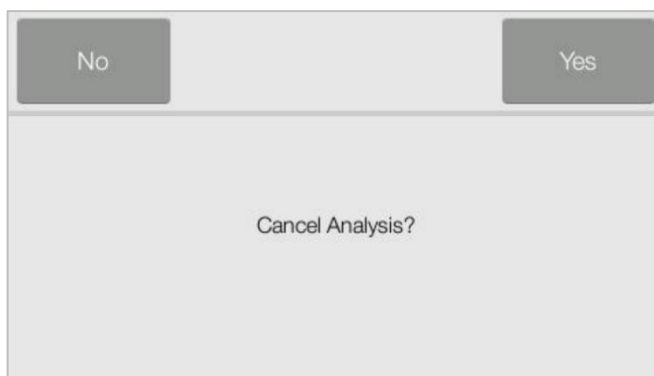

1. If you need to cancel the analysis, press **'Cancel'** on the screen. A confirmation prompt will appear, asking if you are sure you want to cancel.

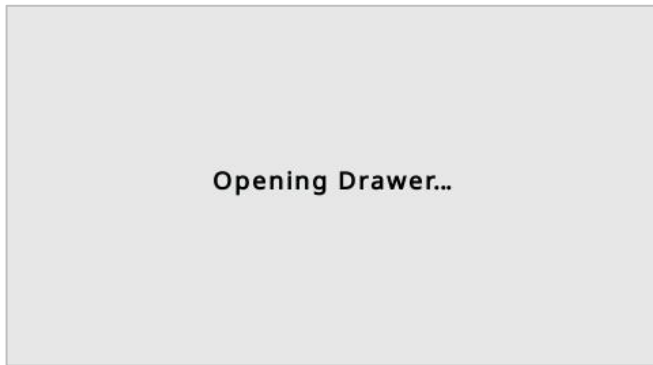

2. After pressing ‘Yes’ to confirm, the analysis will be cancelled and the drawer will open automatically.

*Note: The Analyzer may take a few minutes to open the drawer while it completes internal procedures.*

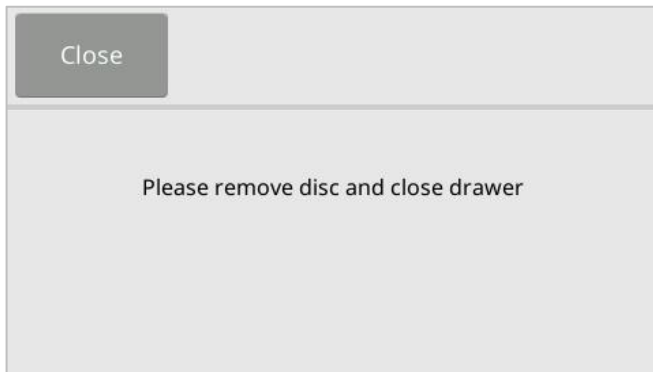

3. Remove the disc from the drawer, then press ‘Close’ to shut it. The analyzer is now ready for another analysis

### 3.6 Report

#### 3.6.1 Report Information

A typical report printout is shown on the right. The heading includes the following information:

- Patient Name
- Owner Name
- ID Number
- Gender
- Age
- Sample Type
- Lot Number

The test results section is organized into five columns:

- Analyte Name
- Analyte Result
- Indicator
- Reference Range
- Specified Units

Species: Dog				
Pet: peipei				
Owner: Ms. Zhang				
ID: 400285				
Gender: Male				
Age: 1year5month				
Sample type: Whole Blood				
LOT: 42546-20-55-171220-1755				
Item Name	Result	Indicator	Ranges	Unit
ALB	5.2	↑	2.5-4.4	g/dL
TP	6.8		5.4-8.2	g/dL
GLO	1.6	↓	2.3-5.2	g/dL
P <sub>1</sub>	29.16	↑	2.9-6.6	mg/dL
CHOL	800	↑	124-271	mg/dL
ALT	≥1500	↑	10-110	U/L
TBIL	0.12		0-0.6	mg/dL
ALP	30		20-150	U/L
CRE	5.82	↑	0.3-1.3	mg/dL
CK	≥5000	↑	20-200	U/L
Lipemia				
Report DateTime: 2017-10-26 03:34				
Operator:				
Reviewer:				
The results relate only to the sample tested				

### 3.6.2 Interpretation of Results

1. Results outside the reference range are indicated by a 'less than' symbol ( $\downarrow$ ) or a 'greater than' symbol ( $\uparrow$ ) next to value.
2. Results outside the dynamic range are marked with:
  - A 'less than or equal to' symbol ( $\leq$ ) next to the lowest value of the dynamic range.
  - A 'greater than or equal to' symbol ( $\geq$ ) next to the highest value of the dynamic range.
3. The symbol '–' replaces numbers when a result is abnormal. Abnormal results may occur due to:
  - Reagent deterioration
  - Interference from endogenous substances (e.g., hemolysis, icterus, lipemia)
  - Interference from exogenous and therapeutic substances
  - Concentrations outside the analyzer's reportable range

When a chemistry result is replaced with '–', the reason will be noted at the bottom of the report. If you encounter this issue, repeat with a new disc. If the result still does not report, please contact the dealer's Technical Support.

4. Samples are checked for physical interference from hemolysis, lipemia, and icterus. If any indices exceed pre-established limits, the corresponding index (HEM, LIP, or ICT) will be printed at the bottom of each result card to inform the operator about potential interference.

**Note:** *If the sample is identified as hemolytic, collect a new sample and run another reagent disc. If the new sample is still hemolytic, use an alternative testing method or send the sample to a reference laboratory.*

**Samples with a haematocrit exceeding 60%packed red cell volume may be marked as HEM on the result card. These samples can be centrifuged to obtain plasma and then re-run using a new reagent disc.**

**High lipemia may result from diet. Ensure the patient has fasted for at least 12 hours before collecting another sample. For grossly lipemic samples from fasting patients or for icteric samples, use an alternative testing method or send the sample to a reference laboratory.**

5. During the analysis process, the analyzer will check the volumes of the sample and diluent. If the volumes of the sample or diluent in the reagent tray are

insufficient, error codes 02081 or 0233 will be reported. The analyzer will prompt to repeat the test with a new reagent tray, following the procedures outlined in **Section 3.3**.

6. In very rare instances, the sample in the reagent disc may fail to be successfully delivered to the reaction cuvettes or may not mix properly with the diluent. In such cases, the analyzer will report error codes 0210, 0211, or 0234. The sample can be retested using a new reagent disc.

### 3.7 Recalling Results

The results obtained by the Analyzer are stored in its memory and can be recalled and printed as needed. If the Analyzer is connected to an external computer or USB storage device, the results can be transmitted to those devices.

The Recall function is accessible from the analyzer’s Main Screen. The operator can search for results by:

- ID
- Patient name
- Date of the results

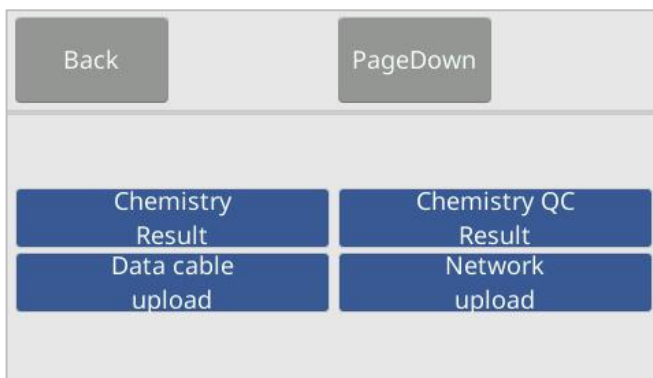

1. On the main screen, press ‘’, The display will show the image on left. Then select ‘**Chemistry Result**’.

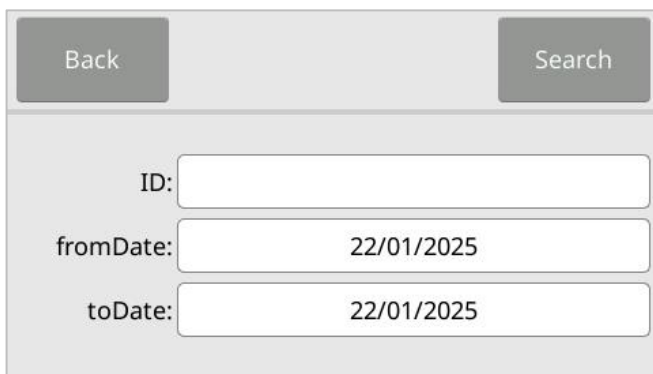

2. Enter the ID or Patient name or the time range to search reports.

Back	PageUp	PageDown	Upload
ID	Date	State	
123456	22/01/2025	pass	
	22/01/2025	error	
123456	22/01/2025	error	
	22/01/2025	pass	

Back

Data cable      Network

Bluetooth      TCP

Back	PageUp	PageDown	Export	
Species: Dog		Patient: qq		
Owner: winy		ID: 123456		
Gender: Male		Age: 1 year		
Sample type: Serum				
LOT: 420033-5-0148-0302-67-240780-1027-2411151532-2411152100				
Item Name	Result	Indicator	Ranges	Unit
NH3	---		0-99	umol/l

3. The analyzer will display a list of reports sorted by the search criteria. To upload the reports to the MNCHIP Data Management Platform, select ‘**Upload**’.
4. After pressing ‘**Upload,**’ the display will show the image on the left. Select an upload path, and the reports will be uploaded automatically.
5. Select a report in the list on **Step 3** to show detailed results.

The Recall function is accessible from the MNCHIP Data Management Platform. Operators can search results by species, gender, age, or ID, or view patient results by date. Please refer to **Section 8** for more details.

## Section 4 Calibration and Quality Control

### 4.1 Calibration

The Pointcare V3 Chemistry Analyzer is calibrated by the manufacturer before shipment. Each time you turn on the power, the analyzer performs a hardware self-calibration. Additionally, each reagent bead in the reagent disc is calibrated against a reference method and/or material prior to shipping. The QR code on the foil pouch of the reagent disc contains specific calibration data for that disc, enabling the analyzer to accurately calculate analyte concentrations. By following the recommended procedures outlined in Section 3, Basic Operations of this manual, you can ensure that the analyte concentrations reported by the analyzer are accurate.

### 4.2 Quality Control

#### 4.2.1 Quality Control During Analysis

During analysis, the analyzer continuously checks its components and the reagent disc to ensure accurate results.

#### **Pointcare V3 Chemistry Analyzer**

Before starting the analysis, the analyzer's photometer performs readings with both obstructed and unobstructed light paths to determine the appropriate light intensity range, ensuring it meets specifications. It also monitors the performance of the motor, flash, and optics throughout the analysis.

#### **Reagent Disc Checks**

The analyzer verifies several factors during analysis:

- Calibration factors
- Expiration date
- Presence of all reagent beads
- Timing of fluid movement through the disc
- Mixing of diluent and sample
- Sufficient sample volume in the disc
- Proper dissolution of reagent beads when mixed with sample

Each reagent disc includes reagents that detect exposure to extreme conditions like temperature and humidity. If these reagents show results within expected ranges, normal test results are printed; otherwise, no results are printed, and "run canceled" appears on the display.

The analyzer also monitors reaction performance:

- For rate chemistries: Confirms reactions are linear over time and slope is within range while monitoring substrate depletion.
- For endpoint chemistries: Verifies flatness (completeness) of endpoints.

### Sample Checks

Samples undergo checks for physical interference by estimating indices such as hemolysis, lipemia, and icterus using absorbance readings at 340 nm, 405 nm, and 467 nm. These values are compared against pre-established limits for each method:

- If all three indices are below limits, results are printed.
- If any index exceeds its limit, results for that method are suppressed with an error condition displayed as HEM (hemolysis), LIP (lipemia), or ICT (icterus).

#### 4.2.2 Quality Control

The performance of either the analyzer or reagent disc can be verified by running controls—biological samples or solutions designed for quality control purposes. The matrix composition must closely match that of biological specimens relevant to the analyzer's characteristics.

Control materials should be stable and available in sufficient volumes over time; many commercial options exist. Assayed controls come with expected analyte values for guidance.

For a list of approved quality control materials with acceptance ranges, please contact Dealer's Technical Support. Note that other human serum or plasma-based controls may not be compatible. Store quality control materials according to instructions in their package inserts.

We strongly recommend following local health regulatory requirements for

quality control testing:

- At least every 30 days
- Whenever laboratory conditions change significantly
- When personnel training or retraining is indicated
- When test results do not align with patient symptoms or clinical findings
- With each new lot of reagents

Samples and controls are analyzed identically by the analyzer; however, using the Controls option stores control results separately from patient results in the database. Control results can be printed immediately after control analysis or recalled later.

Handle controls as described in their package insert. For assistance interpreting control results, please contact dealer's Technical Support. The analyzer automatically stores control results separately from patient data memory; use the Recall function to search specific control results without sifting through all patient data.

**Note: Discs are fragile—always handle them carefully! Do not tap discs on surfaces or use them to empty samples; avoid using any disc that has been dropped. Inspect each reagent disc for damage before use—never use a damaged disc.**

## 4.3 Control Analysis

### 4.3.1 Control Analysis

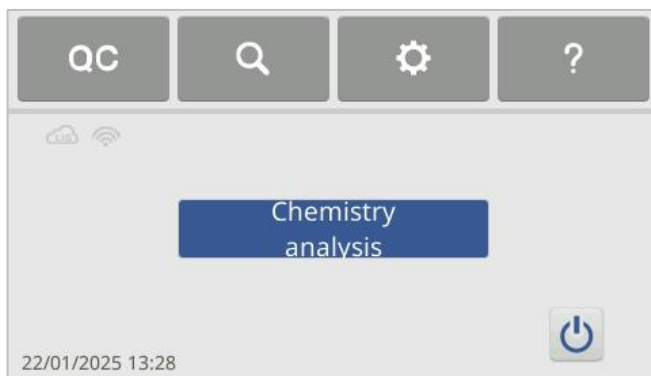

1. On the Main screen, press 'QC'. Controls can be accessed at any time while the analyzer is displaying the Main screen.

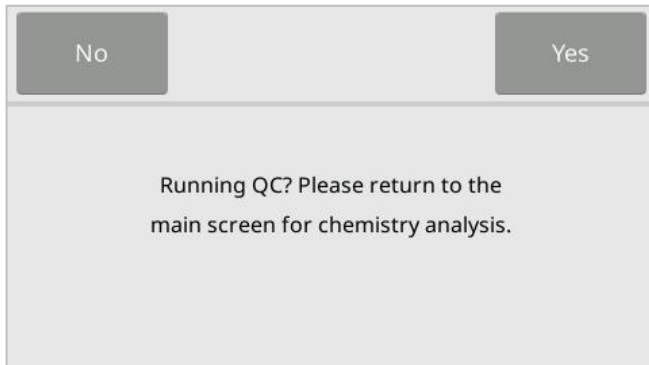

2. Click ‘QC’ to open the confirmation interface for quality control. Selecting ‘Yes’ will start the quality control process.



3. Choose the matrix type of the quality control material according to the project you are going to perform.

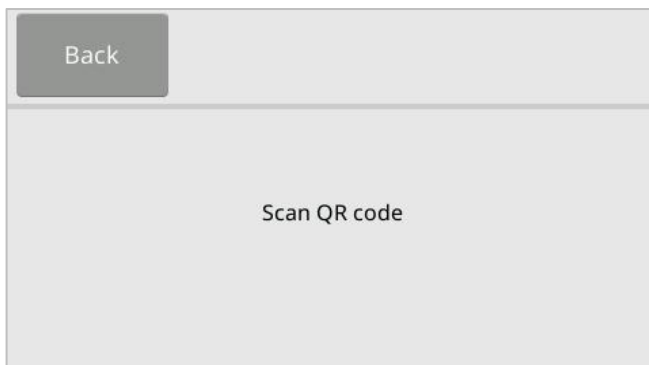

4. Scan the QR code on the foil pouch of the reagent disc, as outlined in **Section 3.4: Sample Analysis**.

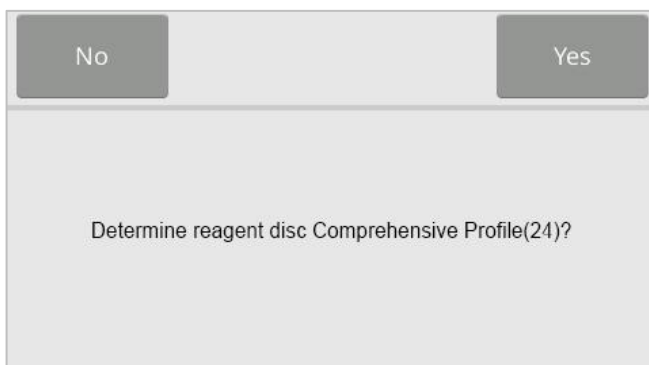

5. According to the instructions in **Section 3.3: Preparation of the Reagent Disc**, add the control solution to the reagent disc. Then, place the reagent disc into the drawer of the analyzer to initiate the analysis.

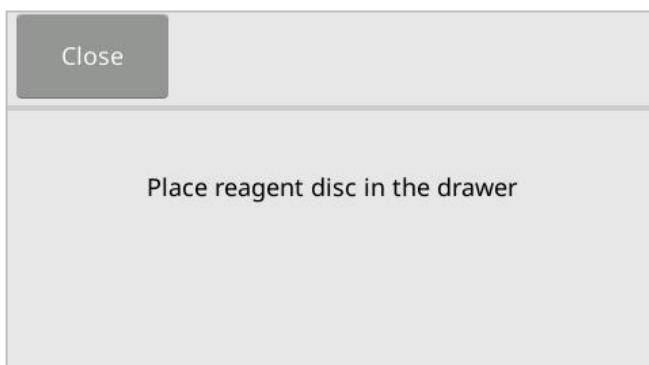

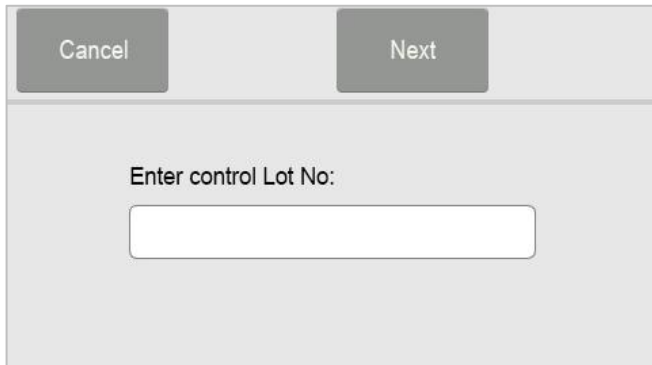

6. Input the control lot number, then press ‘ **Next** ’ to display the progress bar with a countdown timer.

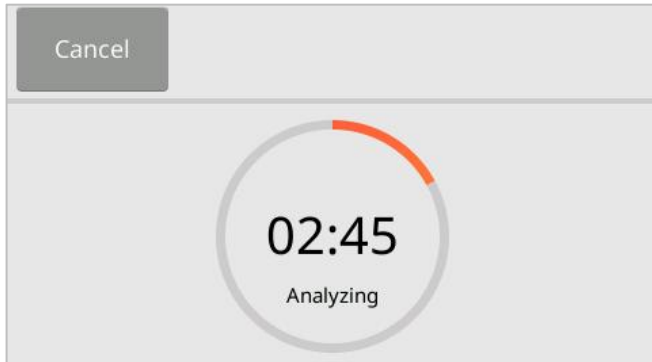

7. Countdown timer.

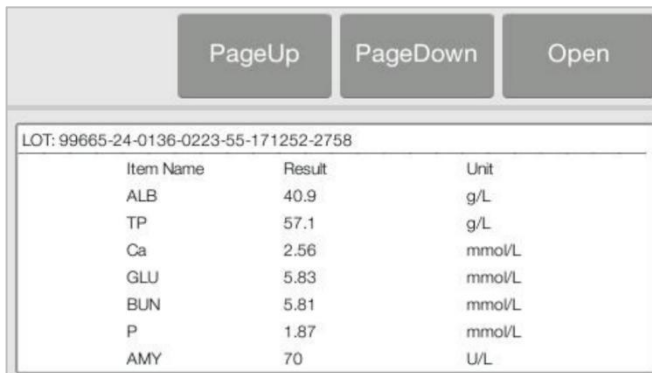

8. After the analysis is complete, the analyzer stores the results in the database. Compare the control result to the range printed on the control data sheet.

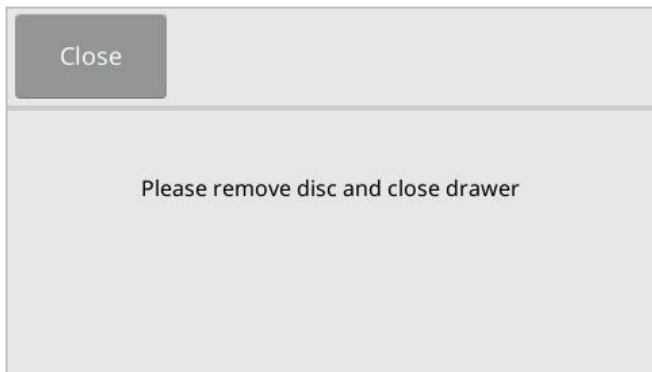

9. Press ‘ **Open** ’ to open the drawer and remove the disc. Then, press ‘ **Close** ’ to shut the drawer and return the analyzer to standby mode.

*Note: If the control results are out of range, repeat the process. If they remain out of range, please contact Technical Support.*

### 4.3.2 Recalling Control Results

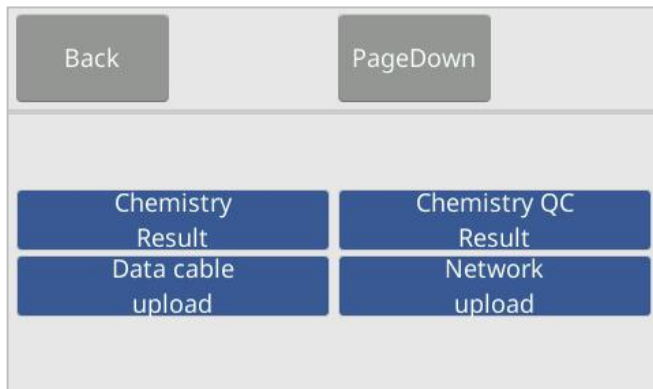

1. On the main screen, press '  ', The display will show the image on left. Then select '**Chemistry QC Result**'

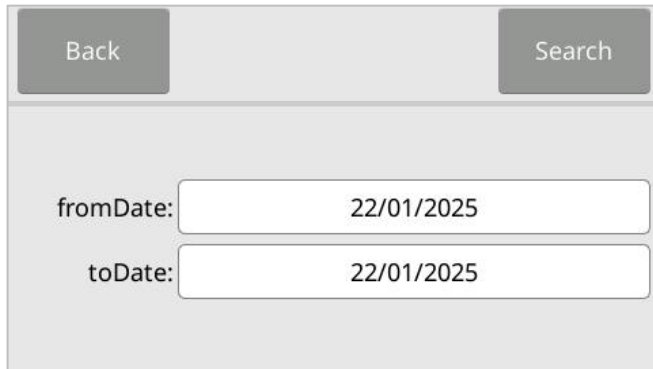

2. Enter the date range to search for control reports.

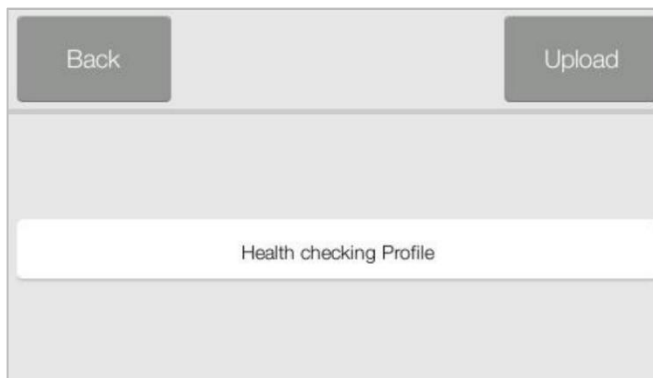

3. Select reagent disc type.



4. Select control Lot number.

Back	PageUp	PageDown	Print
LOT: 99665-24-0136-0223-55-171252-2758			
Item Name	Result	Unit	
ALB	40.9	g/L	
TP	57.1	g/L	
Ca	2.56	mmol/L	
GLU	5.83	mmol/L	
BUN	5.81	mmol/L	
P	1.87	mmol/L	
AMY	70	U/L	

5. The detailed results of the specific control report will be displayed. Press **'Print'**.

## Section 5 Configuring the Analyzer

This section describes how to configure the analyzer.

### 5.1 Analyzer Information

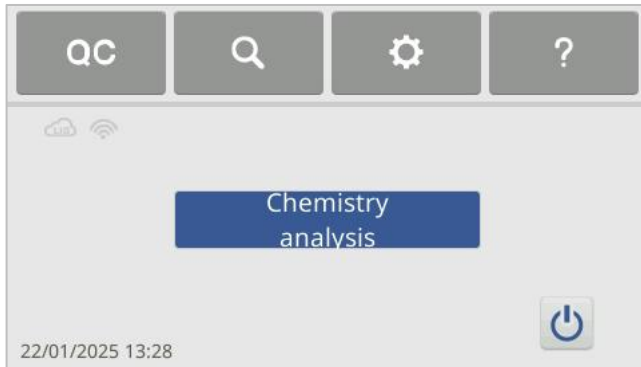

1. On the Main Screen, press ‘’, Then press ‘**Network**’.

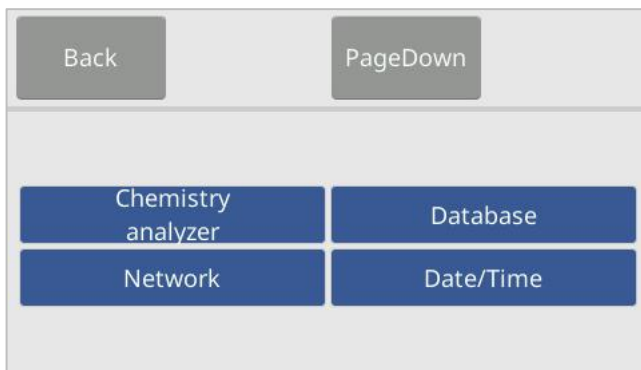

2. Then press ‘**Chemistry analyzer**’.



3. The display will show the analyzer information, such as serial number, the version of the installed software and upload log. Press ‘**Update**’ to install the latest version. Click ‘**Privacy Policy**’ to read the content.

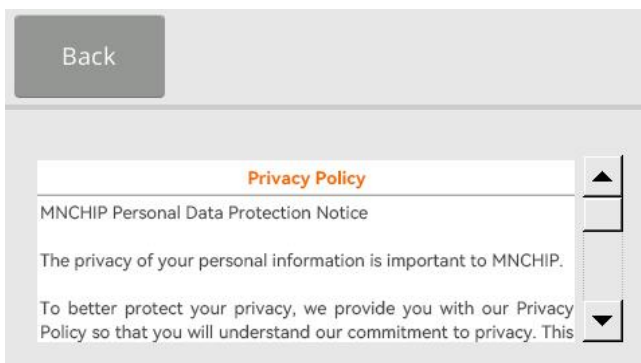

## 5.2 Network Connection

The analyzer features a built-in Wi-Fi module. Connecting to the internet allows for automatic software updates and the uploading of error logs to a cloud server. Technical support engineers can diagnose issues with the analyzer through the error logs.

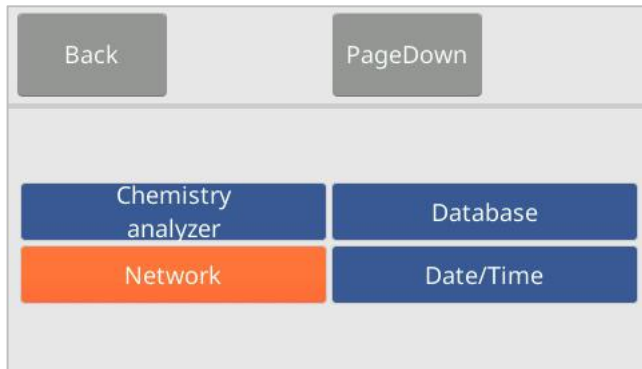

1. On the Main Screen, press ‘’, Then press ‘**Network**’.

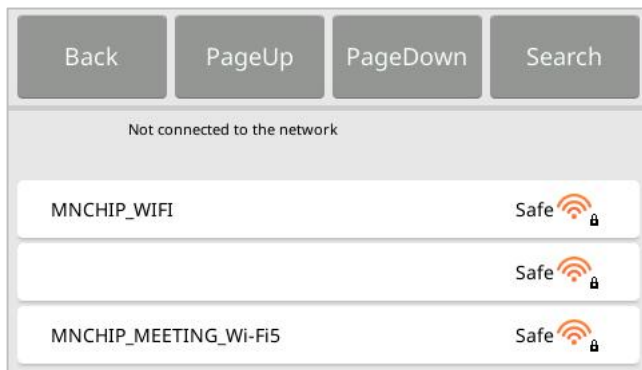

2. Press ‘**Scan**’ to display the network list. Select a wireless network from the list.

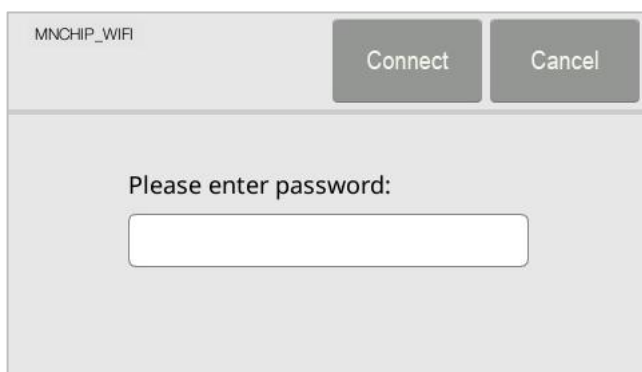

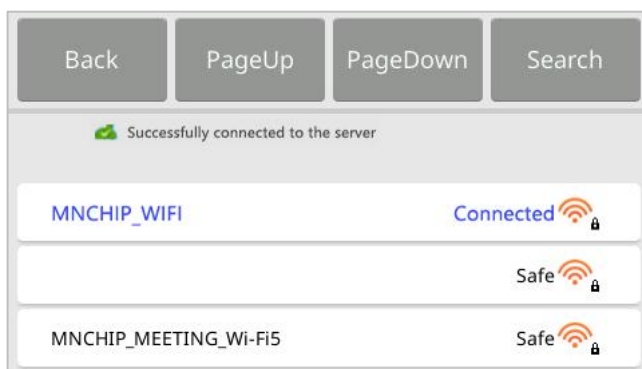

3. If you are connecting to a secured network, enter the password ,Then press ‘**Connect**’.

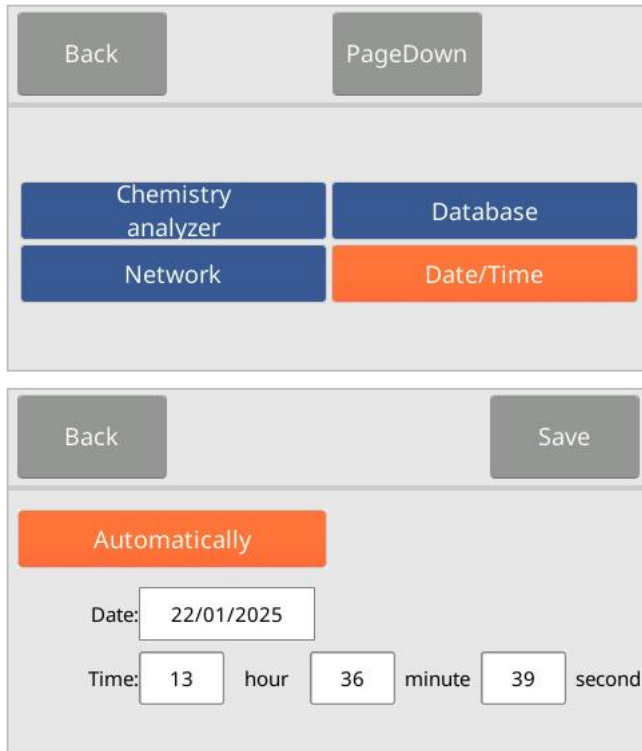

4. The display shows the following.

### 5.3 Changing Date and Time



1. On the Main Screen, press ‘’, Then press ‘**Date/Time**’.
2. The display will show the Set Date/Time screen. The network time will automatically synchronize when connected.
3. Select year, month and day on the calendar, input the hour, minute and second.
4. Press ‘**Save**’ when Date/Time is set screen.

### 5.4 Report Layout

The operator can customize the reported content using the Report Layout feature.



On the Main Screen, press ‘’, then press ‘**Report**’.

### Hospital Name

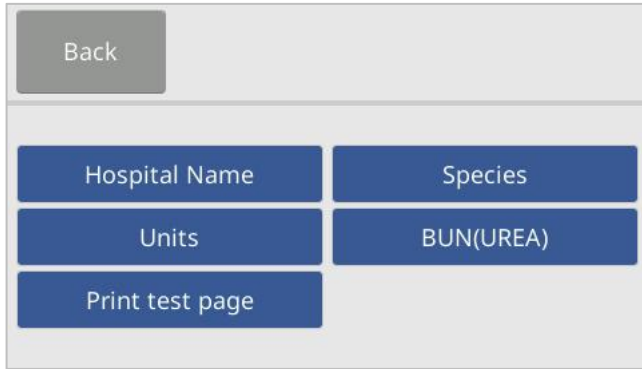

1. Press **‘Hospital Name’**

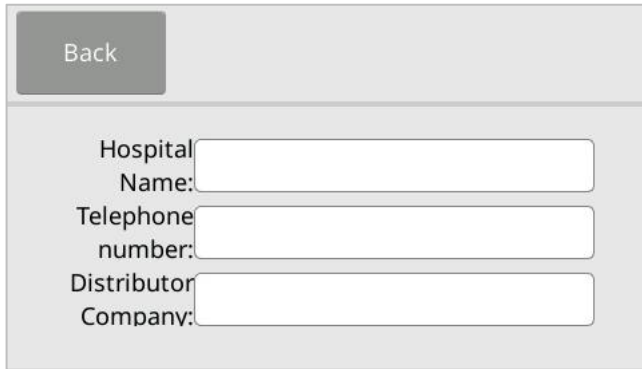

2. Enter the hospital name to be displayed on the report. Then enter the telephone number and distributor company, and press **‘Back’**.

**Species: Adding and deleting species; setting reference ranges for species.**

The analyzer is pre-set with multiple species and their corresponding reference ranges at the factory. Operators can add or delete species as needed for diagnostics and may also modify the default reference ranges.

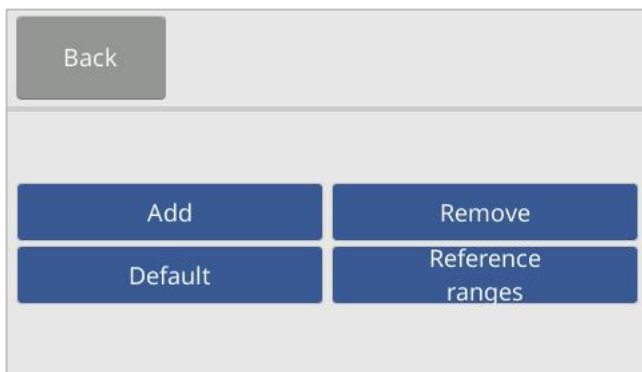

1. On the Main Screen, press **‘’**, → **‘Report’** → **‘Species’**. Then the screen displays options for users to add or remove a species, or view the reference ranges list.

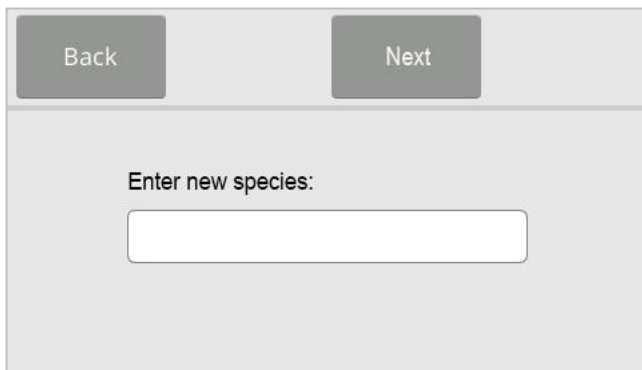

2. Press **‘Add’** and input the species name to add a new species. Press **‘Next’** to select **‘Juvenile’** or **‘Adult’**.

Back

Young      Adult

Back      PageDown      Save

ALB	<input type="text" value="0"/>	<input type="text" value="0"/>	g/L
ALP	<input type="text" value="0"/>	<input type="text" value="0"/>	U/L
ALT	<input type="text" value="0"/>	<input type="text" value="0"/>	U/L
AMY	<input type="text" value="0"/>	<input type="text" value="0"/>	U/L

3. Input reference ranges, press **'Save'**.

Back

Add      Remove

Default      Reference ranges

4. As in **Step 2** press **'Remove'**.

Back      PageDown

Dog      Cat

Rabbit      Rat

Mouse      Monkey

5. Click **'Page Up/Page Down'** to browse, then select target species for deletion.

No Yes

Remove 'Dog'?

6. After pressing **'Yes'** to confirm, the selected species will be removed.

Back

Add Remove  
Default Reference ranges

7. As in Step 2 press **'Reference ranges'**.

Back PageDown

Dog Cat  
Rabbit Rat  
Mouse Monkey

8. Select a species, then choose either **'Young'** or **'Adult'** to display the parameters list.

Back PageDown Save

ALB	22	44	g/dL
ALP	40	300	U/L
ALT	10	140	U/L
AMY	400	3500	U/L

9. Use **'Page Up/Page Down'** to go through the list. Input values and press **'Save'** to store the changes.

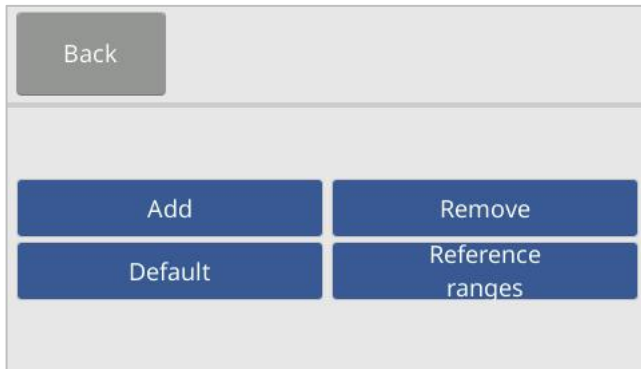

10. As in step 2 press **'Default'** . Press **'Yes'** to load factory default.

## Print Test Page

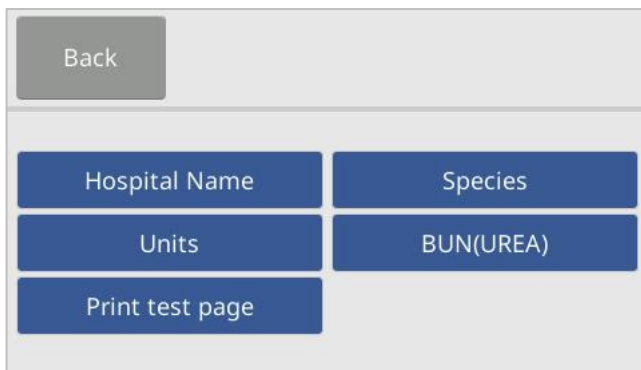

1. Click **"Report"** access the report settings interface . Click **"Print test page"** to test whether the analyzer is successfully connected to the external printer and whether the printing function is normal.

## Units

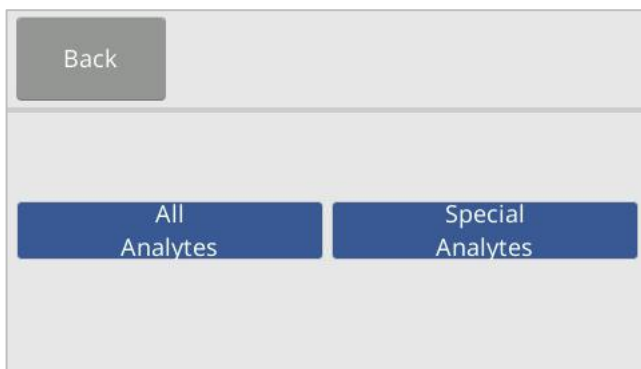

1. On the Main Screen, press **'Setting'** → **'Report'** → **'Units'**. Different unit settings can be selected based on the item.

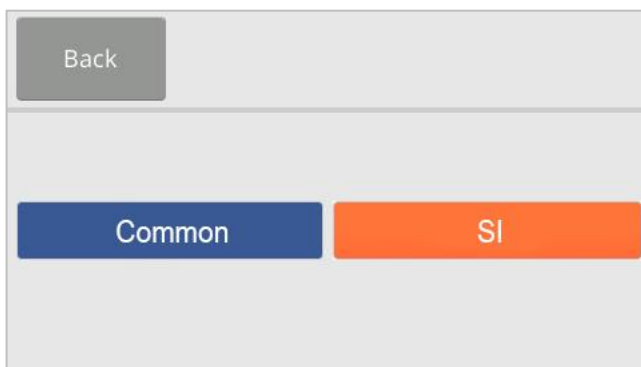

2. Selecting **'All Analytes'** allows the unit for all items to be set to either metric or imperial units; selecting **'Special Analytes'** enables the unit setting for specific items.

## BUN(UREA)



1. This setting primarily determines the name used to represent this item in the report, and it can be configured according to user preferences.

## 5.5 Setting Sound



1. On the Main Screen, press '⚙️', Then press '**Sound**'.



2. The user can select '**Sound**', '**Silent**', or '**Key Tone**'. '**Sound**' refers to the prompt tone when opening the analyzer and completing the analysis. '**Key Tone**' is the prompt tone for

## 5.6 Setting Language



1. On the Main Screen, press '⚙️', Then press '**Language**'.

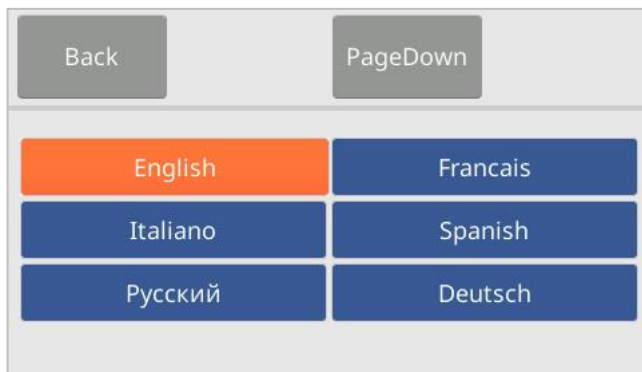

2. The user can select the language required.

## 5.7 Sample Type



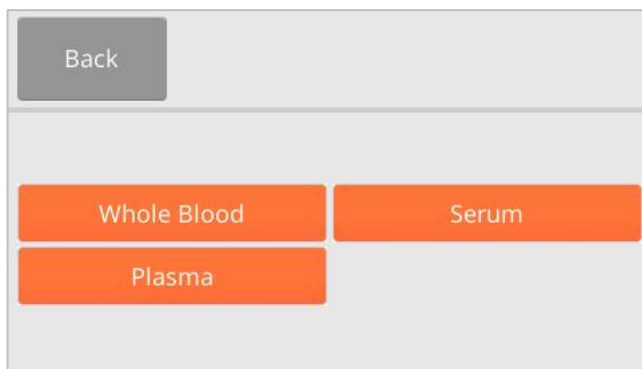

1. On the Main Screen, press '' , then select '**Sample Type**'.

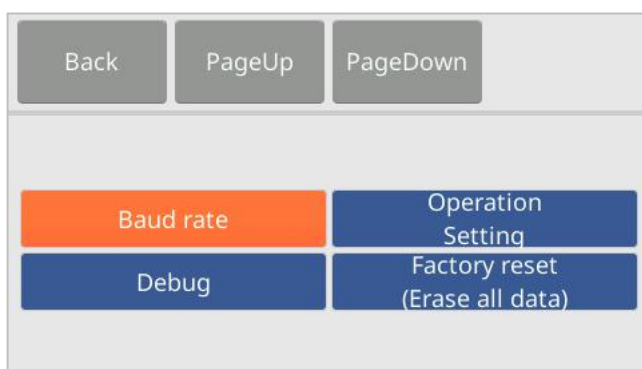

2. The user can select '**Whole Blood**', '**Serum**' and '**Plasma**' testing mode.

## 5.8 Setting Baud Rate



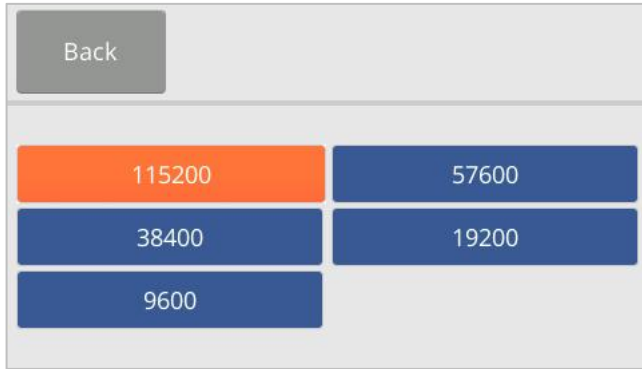

1. On the Main screen, press '' , then press '**Baud rate**'.

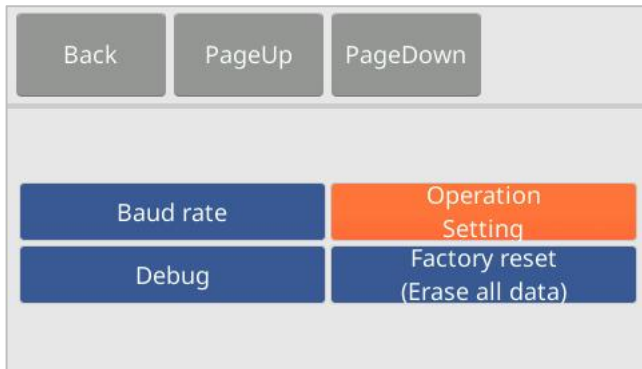

2. The user can select one mode. The default value is 115200.

### 5.9 Operation Settings



1. On the main interface, select '  ', then click the 'Operation Setting' button. In the resulting interface, there are options for 'Blue Film' and 'Water Box'.



2. Click the 'Blue Film' and 'Water Box'. This selection will trigger relevant operations during the procedure.

### 5.10 Setting LIS Function

The device can connect to LIS via serial cable, Ethernet (using the device's network port), or wirelessly (Wi-Fi, internal local area network).

The prerequisites for this functionality are:

- The device must be correctly connected to the Ethernet or wireless network.
- The device's IP address must be reachable from the LIS server's IP.
- The LIS system must be capable of receiving data over the network. (Our company can provide the LIS protocol documentation and HTTP LIS

Integration protocol documentation; the LIS vendor is responsible for integration and ensuring the functionality of the LIS system.)

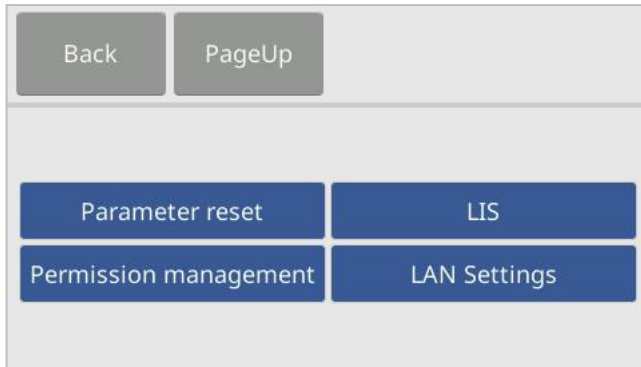

1. Click the ‘’ button on the main interface, then click the ‘**LIS**’ button.

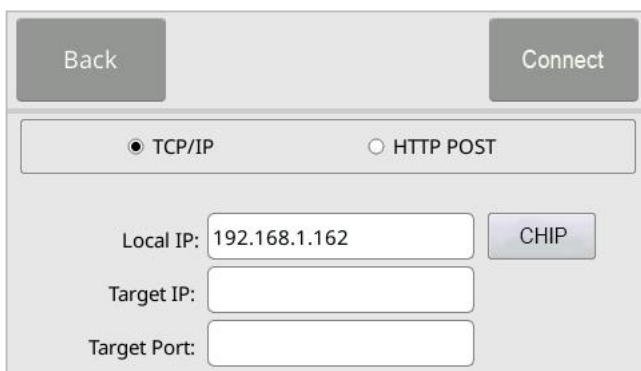

2. After selecting the communication method as ‘**TCP SOCKET**’ or ‘**HTTP POST**’ the ‘**Device IP**’ will be displayed automatically. The LIS engineer will then enter the ‘**Target IP**’ and ‘**Target Port Number**’ which refer to the IP address and port of the LIS server.

*Note: If the customer's environment does not support DHCP, the ‘Device IP’ will not be displayed automatically and must be entered manually.*

After filling in the information, click the ‘**Connect**’ button in the upper right corner.

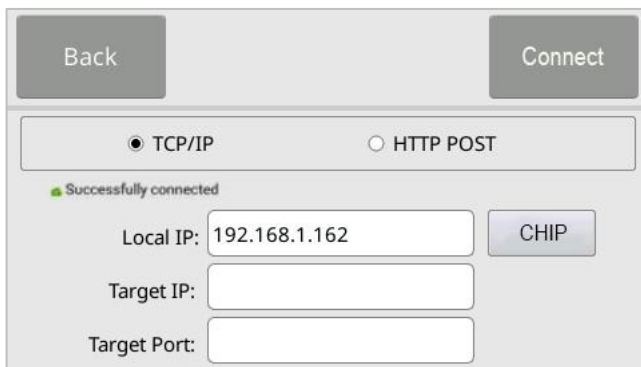



3. If the connection is successful, a message will appear on the screen saying ‘**Successfully connected**’ and it will connect automatically next time. After a successful connection, the icon on the main interface will light up.

## 5.11 Permission Management

The permission management accounts are divided into two types: administrator accounts and regular accounts. Administrator permissions allow login to the device, adding or deleting regular user accounts, modifying passwords for all accounts, and viewing test records under all accounts; regular user permissions allow login to the device and viewing test records under their own account.

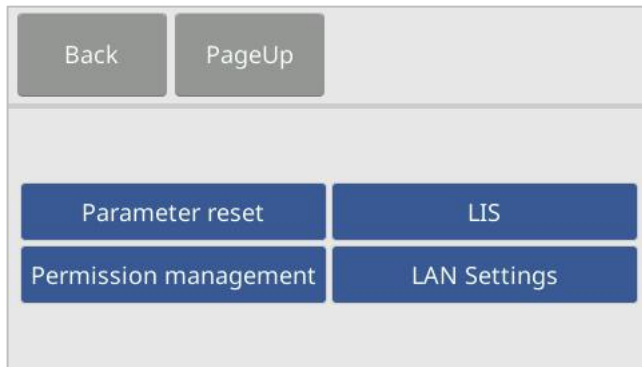
### 5.11.1 Enable the 'Permission Management' feature.



1. On the main Screen, click on '  ', then navigate to the '**Permission Management**' button. Check the box for '**Enable Permission Management**', click '**Confirm**' to confirm, and proceed to the administrator account registration interface.

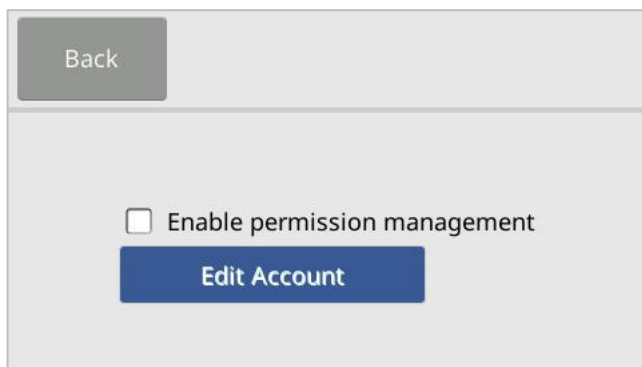

2. After enabling this feature, you can set the administrator password. Once you enter the password, click 'Yes' to complete the administrator setup. At this point, you can click on '**Edit Account**' on the screen to modify account information

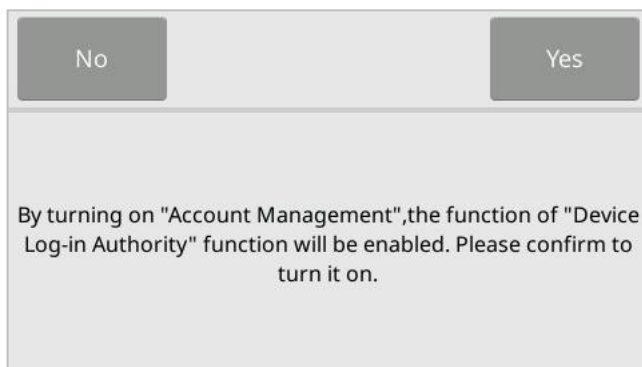

3. The default administrator account name is **'admin'** (which cannot be changed). Enter the password and confirm it, then click the **'Save'** button. A popup will appear indicating that the **'Permission Management'** has been successfully enabled.

4. Click **'Yes'** to restart the device. Once the device restarts, the **'Permission Management'** feature will be activated automatically.

*Note: It's crucial to securely store the administrator account password; once lost, it's irretrievable.*

### 5.11.2 Account login and account switching.

1. Once **'Permission Management'** is activated, the device will show the account login interface at startup. Click on the blank box next to **'Account'** select your username, enter the corresponding password, and then click the **'Login'** button to access the main interface.

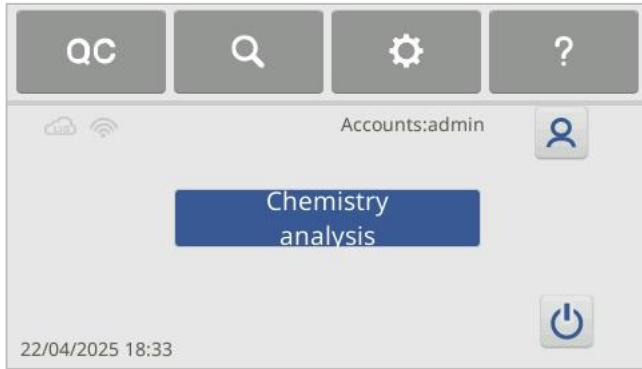

2. The current account name is displayed in the upper right corner of the device's main interface. To switch accounts, click the ‘  ’ button in the upper right corner. You can then select a different username and enter the password to log in.

### 5.11.3 Administrator Account Password Modification

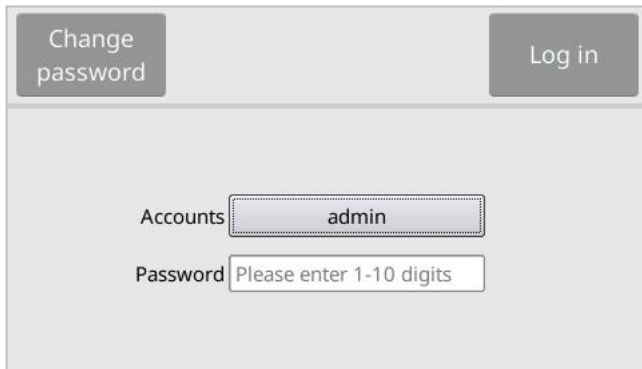

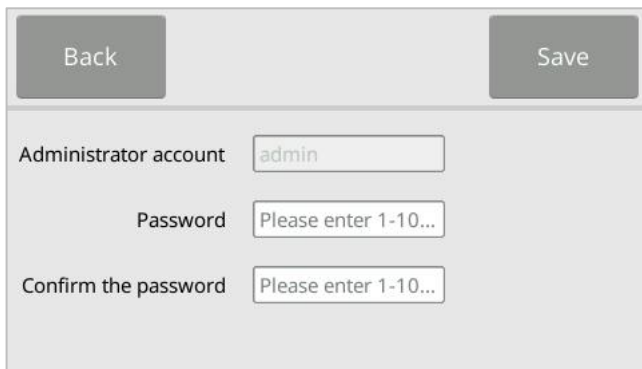
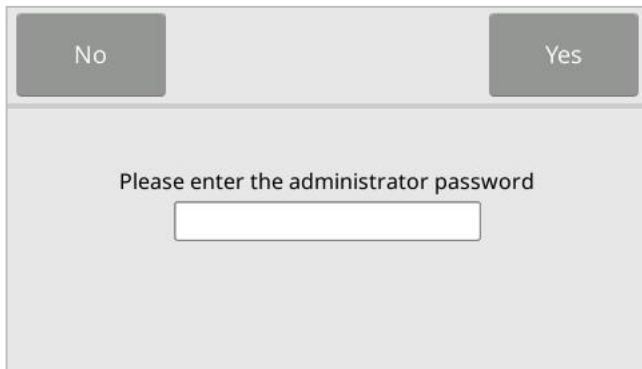

1. On the account login interface, click the ‘**Change Password**’ button in the lower left corner. Enter the original password, click ‘Yes’, and you will be taken to the password modification interface.

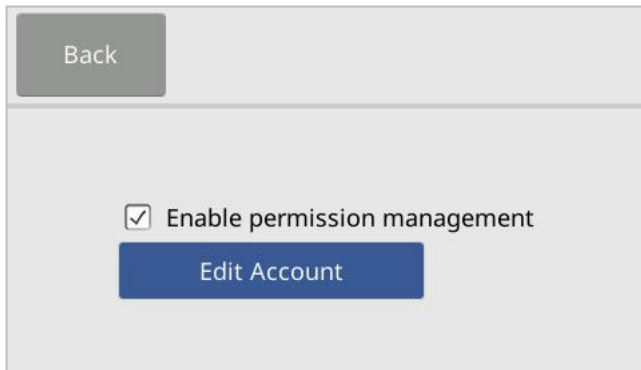

2. Enter the new password and confirm it, then click the ‘**Save**’ button in the lower right corner. The administrator account password has been successfully modified. Please use the new password for subsequent logins.

5.11.4 Standard account management: adding, removing and editing of account information



1. Access the '  ' → '**Permission Management**' interface using either an Administrator or a Standard account.
2. Click the '**Edit Account**' button, input the Administrator password, and click 'Yes' to enter the account editing interface.

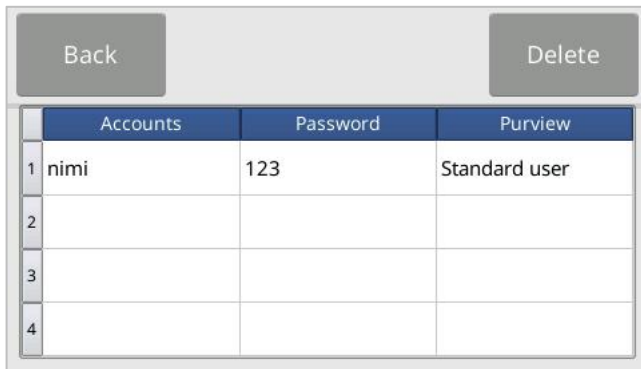
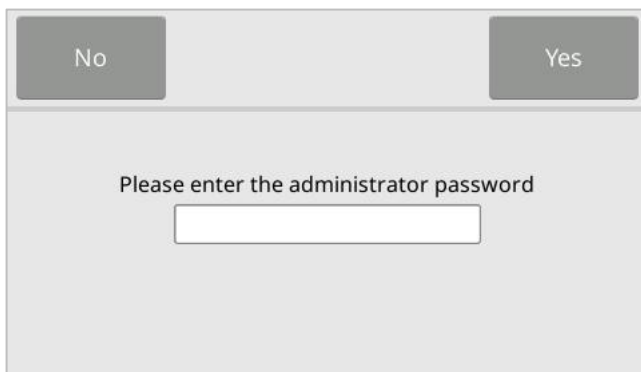

3. In this interface, you can add or delete Standard accounts and change the passwords of existing Standard accounts.

5.11.5 Deactivating the Permission Management function.

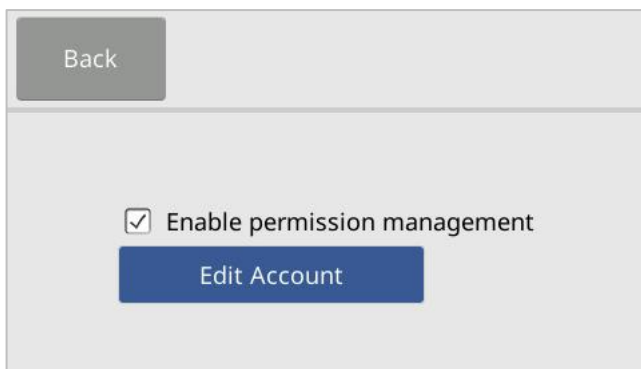

1. For any account (administrator or regular), navigate to the 'Permission Management' interface and uncheck the 'Enable permission management' option.

A confirmation dialog box with a grey background. At the top, there are two buttons: 'No' on the left and 'Yes' on the right. Below the buttons, the text reads 'Please enter the administrator password'. Underneath the text is a white rectangular input field.

2. Enter the administrator password and click 'Yes' to disable the 'Permission Management' function. The change will take effect after the device restarts.

## 5.12 LAN Settings

The device supports transmitting test results to the MNCHIP Medical Data Management Platform via LAN.

A LAN can be configured using the following common methods:

- Connect the device and computer to the same WiFi network;
- Directly connect the device and computer via an Ethernet cable.
- Ensure both the device and computer are on the same LAN through a switch or router.

A screenshot of the LAN Settings screen. At the top, there are two buttons: 'Back' on the left and 'Save' on the right. Below the buttons, there are two radio buttons: 'Automatic' (which is selected) and 'Manual'. Underneath, there are two input fields: 'IP' with the value '192.168.1.9' and 'Port' with the value '49111'.

1. Access the '  ' → 'LAN Settings'. By default, it automatically obtains IP and Port settings upon startup. If auto-configuration fails, switch to manual mode for editing.

A screenshot of the LAN Settings screen, similar to the one above but with the 'Manual' radio button selected. The 'IP' field contains '192.168.1.9' and the 'Port' field contains '49111'.

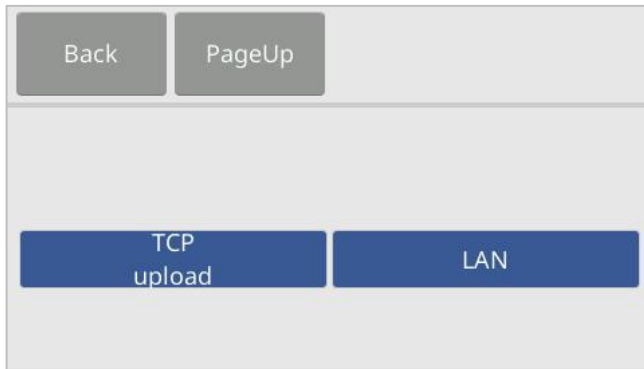

2. After completing biochemical testing, users can select ‘LAN’ to upload results. The ‘LAN’ option is also available for upload in the ‘Result Query’ section.

### 5.13 Other Settings

The analyzer also allows for additional settings, such as ‘**Database**’, ‘**Factory reset**’, ‘**Debug**’ or ‘**Parameter reset**’, These functions can be adjusted after entering a password prior to the settings.



- a. Parameter reset: Restore to the factory settings in ‘Setting’.
- b. Default: Restore factory settings to clear all data from the analyzer.
- c. Database: Backup or delete the database.
- d. Debug: Debugging for factory parameters of the device

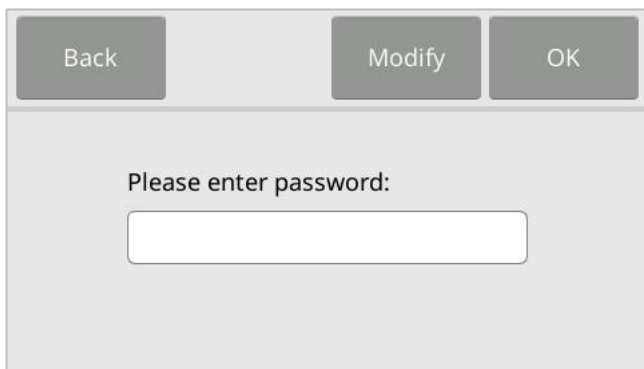

## Section 6 Troubleshooting

### 6.1 Electrostatic Discharge

If the analyzer experiences an electrostatic discharge while running a sample, it may crash. Follow these steps:

- Cancel the test immediately if it times out or the countdown timer stops.
- Turn off the analyzer.
- Wait a few minutes, then turn it back on.

The analyzer should return to normal operation after this procedure.

### 6.2 Error Codes for Analyzer and Troubleshooting

The analyzer can display warning and error codes when issues arise. These codes help Dealer’s Technical Support diagnose the problem. Before contacting support, please follow these steps:

- Update the log.
- Provide the serial number.

Error code	Problem Description	Solution
0101	Multi-switch fault	For any inquiries, please contact us:  <b>E-mail:</b> <a href="mailto:service@mnchip.com">service@mnchip.com</a>  <i>Note: Refer to the Maintenance Manual (Authorized dealers only).</i>
0102	+12Vpower fault	
0103	-12Vpower fault	
0105	AD (AD fault)	
0107	Optical module fault	
0108	LED fault	
0202	Drawer open fault	
0203	Drawer close fault	
0206	Motor speed fault	
02132~02135	Temperature control module fault	
0214	Optical components contamination	
0215	Software error	
0216	Software error	

0220	Temperature data transmission fault
0221	PT100 fault
0222	Upper NTC fault
0223	Lower NTC fault
0224	Upper heating film fault
0225	Lower heating film fault
0301	Firmware 2 fault.
0302	Scan module fault
0303	Firmware 1 fault.

### 6.3 Error Codes for Reagent Disc and Troubleshooting

Error Code	Problem Description	Solution
02081	Insufficient sample	According to Section 3.3 operation requirements, add enough sample and diluent, repeat the analysis with a new reagent disc
0233	The diluent container is not opened properly	
0210	Reagent disc fault	
0211	Reagent disc fault	
02133	The temperature control system fault	Please check whether the ambient temperature range is 10-30 °C
02134	The temperature control system fault	Please clean or replace the dust-proof sponge
0231	Hemolysis	Please collect a new sample for testing
0232	Lipemia	Recommend to repeat the analysis with a new disc after high-speed centrifuge of the sample
0234	Reagent disc fault	Please repeat the analysis with a new reagent disc
0238	Reagent disc fault	Please repeat the analysis with a new reagent disc

## Section 7 Maintenance

The analyzer requires minimal maintenance. To ensure reliable operation, follow these steps:

- Clean the outside of the analyzer weekly with a mild detergent and a soft, damp cloth.
- Clean the air filter once a month.

### 7.1 Cleaning the Analyzer

#### Cleaning the Case

- Use a soft cloth dampened with one of the following:
  - Mild, non-abrasive detergent
  - 10% bleach solution
  - 30% isopropyl alcohol solution
- Do not spray or pour any cleaning solutions directly onto the analyzer.

#### Cleaning the Display

- Periodically clean the screen with a soft, lint-free cloth dampened with glass-cleaning fluid or window cleaner.
- To disinfect, use a 10% bleach solution:
  - Apply the solution to a lint-free cloth and then wipe the screen.

*Note: Avoid cleaners containing alcohol. Do not spray cleaner directly onto the display; always dampen the cloth first.*

### 7.2 Cleaning the Air Filter

The air filter at the rear of the analyzer should be cleaned once per month. If the analyzer is in a dusty or dirty environment, check and clean the air filter more frequently.

- Unplug the analyzer and disconnect the power cord from the rear.
- Open the fan cover and remove the black mesh filter.
- Wash the filter in warm, soapy water and ensure it is completely dry.

- Reinsert the clean, dry filter into the fan and secure the fan cover.
- Reconnect the power cord to the rear of the analyzer.
- Plug the power cord into a power source.

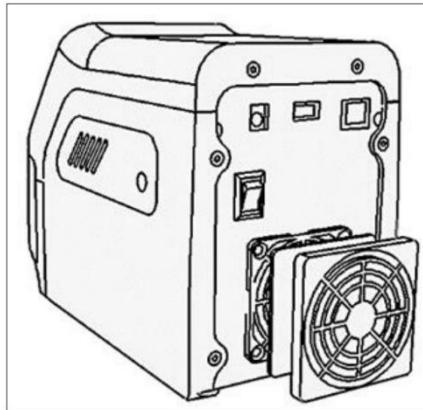

## 7.3 Updating the Analyzer Software

MNCHIP provides software updates for registered analyzers through its server. When a new software version is released, it will be uploaded to the MNCHIP server immediately.

### 7.3.1 Automatic Update

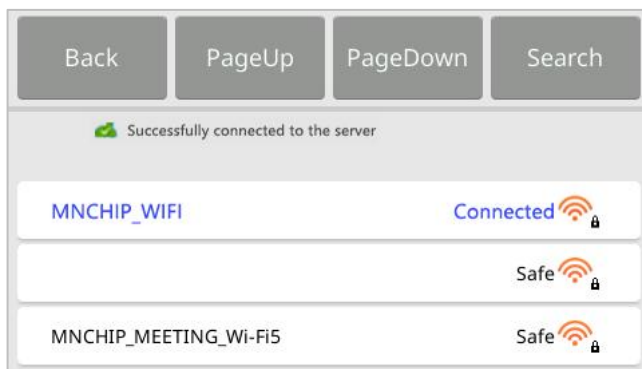

1. Connect to a Wi-Fi network by following the procedure outlined in **Section 5.2 'Network'**.

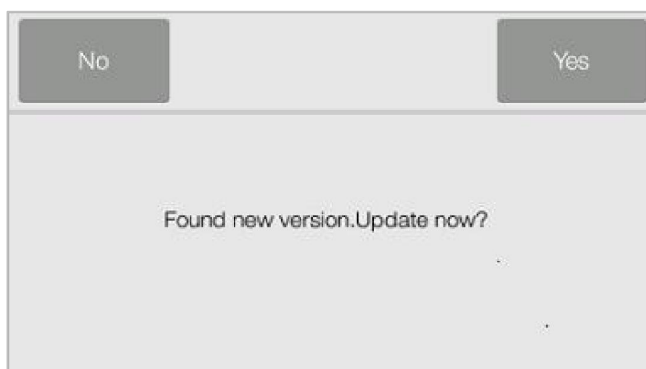

2. A 'new version' window will pop-up automatically when a new version of the software is available.
3. Press 'Yes' to confirm.

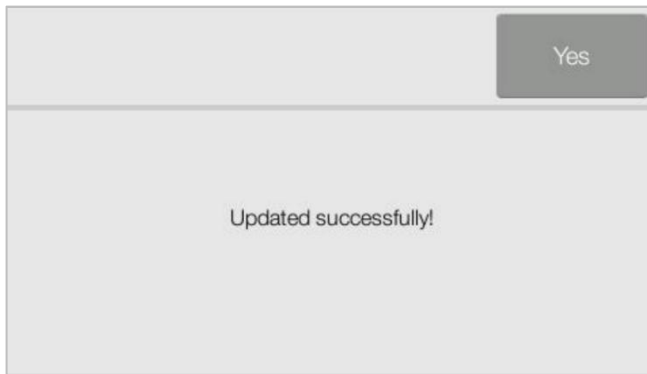

4. After pressing 'Yes' to confirm, when updated successfully, the analyser will reboot.

### 7.3.2 Manual Update

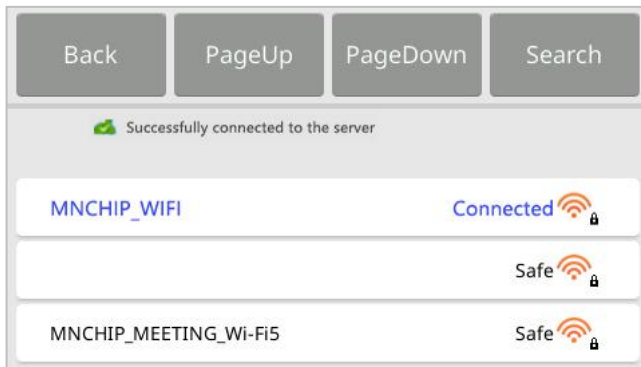

1. Connect to a Wi-Fi network following the procedure in **Section 5.2** 'Network'.

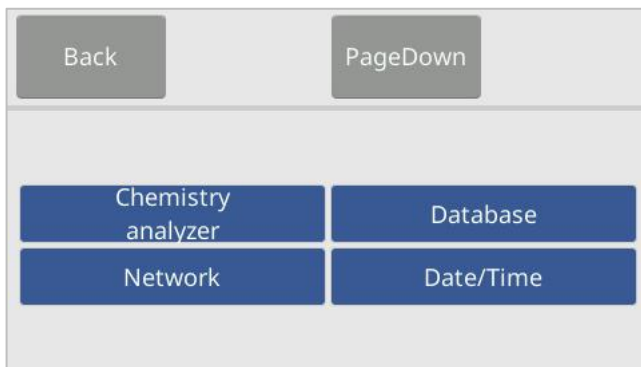

2. In Main Screen, press '⚙️', and then press 'Analyze'.



3. Enter the device information interface and press 'Update' to update the software version or any hardware version.

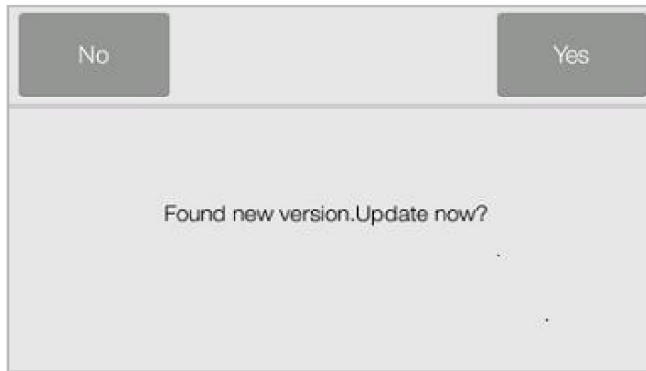

4. A ‘ new version ’ window will pop-up.
5. After pressing ‘ **Yes** ’ to confirm when updated successfully, the analyzer will restart.

**Caution:** Do not disconnect the network or turn off the Analyzer until the update is complete.

### 7.3.3 USB Drive Update

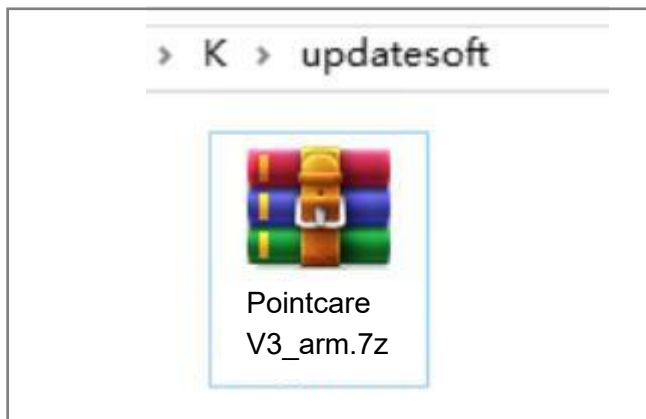

1. Alternatively, you can update the operating system using a USB drive.

**Note:** We strongly recommend using a *Kingston USB drive*, as it is compatible with the Analyzer.

2. Please contact Dealer’ s Technical Support to receive the software via email. After downloading, copy the software to the root directory of your USB flash drive named ‘**updatesoft**’. For example:

**K:\updatesoft\Pointcare V3\_arm.7z**

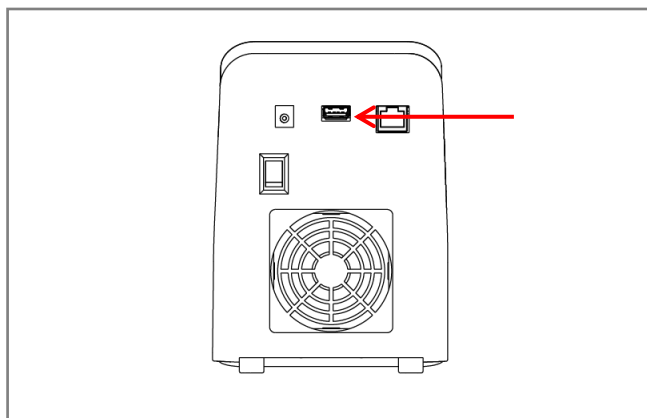

3. Insert the USB drive into the USB port located at the back of the device.
4. For subsequent operations, please refer to the ‘**7.3.2 Manual Update**’ .

**Caution:** Please do not insert the USB drive anywhere except the device for avoiding virus infection.

## 7.4 Installing Thermal Printer Paper

1. Open the printer cover.
2. Remove the thermal paper package and remove a few centimetres of paper.
3. Place the paper in the printer in the direction shown with the non-printing surface is in contact with the rubber roller.
4. Close the printer cover and make sure to expose a few centimetres of paper.
5. Remove the exposed paper.

***Note: After installation, the thermal side of the paper should face down. If the paper is installed incorrectly, it will not print the report.***



## Section 8 MNCHIP Medical Data Management Platform

### 8.1 MMDMP

The MNCHIP Medical Data Management Platform (MMDMP) is Windows-based software that interfaces with the MNCHIP Automated Chemistry Analyzer. Its primary role is to receive and manage data from the analyzer.

#### Key Functions:

- Set hospital name
- Select language
- Edit patient information
- Query and print results
- Configure printer settings
- Export test results
- And more
- Clean the air filter once a month.

### 8.2 Cleaning the Analyzer

#### 8.2.1 How to Obtain the Software?

The MMDMP installer is available on the MNCHIP website:

1. Visit the website:<http://www.mnchip.com>
2. Navigate to the Reference Center.
3. Download the MMDMP installer

*Note: If the above method is not convenient, please obtain the installer from an after-service engineer.*

#### Contact Information:

- Email:[service@mnchip.com](mailto:service@mnchip.com)

#### 8.2.2 Setting up the MMDMP

*Note: Some anti-virus software may affect the installation. For the installation process, it is recommended to turn off anti-virus software.*

**Note: The MMDMP can be installed on the system of Windows7, Windows8, Windows10. Please do not install on Windows XP, otherwise it may cause some errors.**



- a. Start the installer, and an installation prompt will appear. Please select the installation language, then click 'OK'.

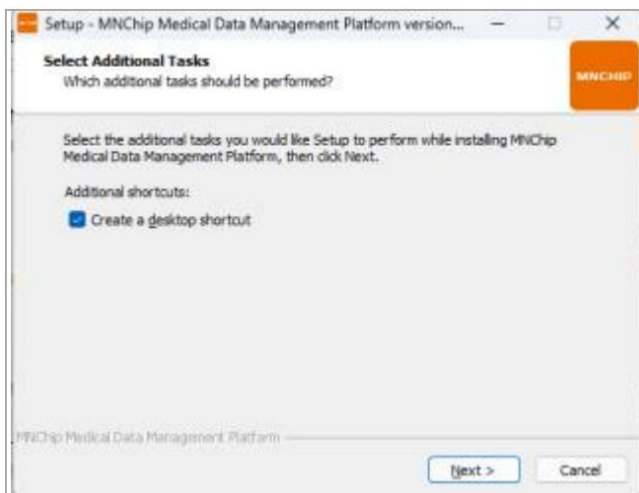

- b. Confirm whether to create a shortcut for the management platform software on the desktop. If you wish to create one, please check 'Create a desktop shortcut' and then click 'Next' to proceed.

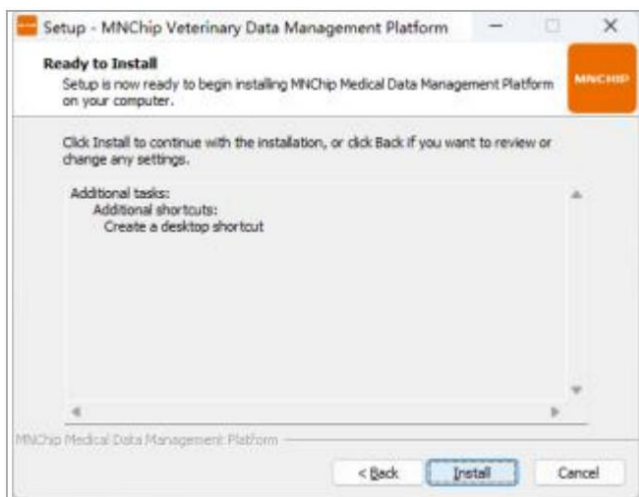

- c. Enter the installation interface and select 'Install'.



- d. Once the installation is complete, a confirmation dialog will appear. Click 'Finish' to complete the installation.

### 8.3 Login

Open the 'MNCHIP Medical Data Management Platform' to access the 'Login' interface.

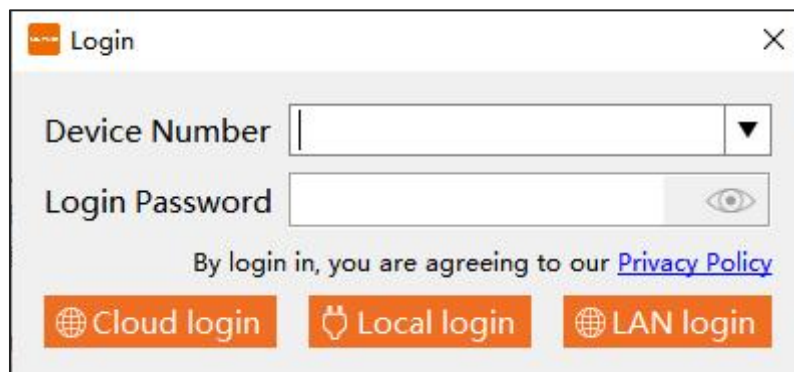

#### 8.3.1 Local login

Use the data cable to connect to the chemistry analyzer and PC. There is no need to enter any information, click 'Local login'.

*Note: Before connecting via the data cable, make sure the analyzer is powered off or rebooted after the connection, otherwise data transfer is not possible.*

#### 8.3.2 Cloud login

When using cloud transmission, ensure that the chemistry analyzer and the PC with MMDMP are connected to the network. The device transmits data to the cloud server via Wi-Fi, and the MMDMP software downloads this data from the server to

the PC.

To view the device ID and login password, navigate to ‘Setting’ → ‘Chemistry analyzer’ on the chemistry analyzer. Enter the complete device ID and login password in MMDMP, then click ‘Cloud login’.

*Note: When you reopen the management platform software, click ‘Cloud Login’. The software will automatically connect to the previously matched device.*

*Note: If the ‘Device Info’ section does not show the loginpassword, it means the device is not connected to the Internet. Please go to ‘Setting’ → ‘Network’ to reconnect.*

## 8.4 ‘Main Screen’ Description

The main interface of the MMDMP is divided into four functional areas, as indicated by the yellow symbols in the figure below:

- **Shortcut Toolbar:** Used for selecting and connecting to data interfaces, backing up and looking up data, setting up configurations, and accessing help.
- **Inspection Information Area:** Displays the currently selected patient information and allows for modifications to related details.
- **Data Selection Area (Patient Info):** Primarily used for selecting a patient report to be printed.
- **Data Display Area (Result):** Mainly shows the patient's results and ranges of the printed content.

When the test result falls within the reference range, the background color is light yellow. If the test result is below the lower limit of the reference range, the background turns blue. When the test result exceeds the upper limit of the reference range, the background changes to red.

If you combine results from different testing equipment (not just this chemistry analyzer), the background will be dark yellow for those additional results. Each column can be edited.

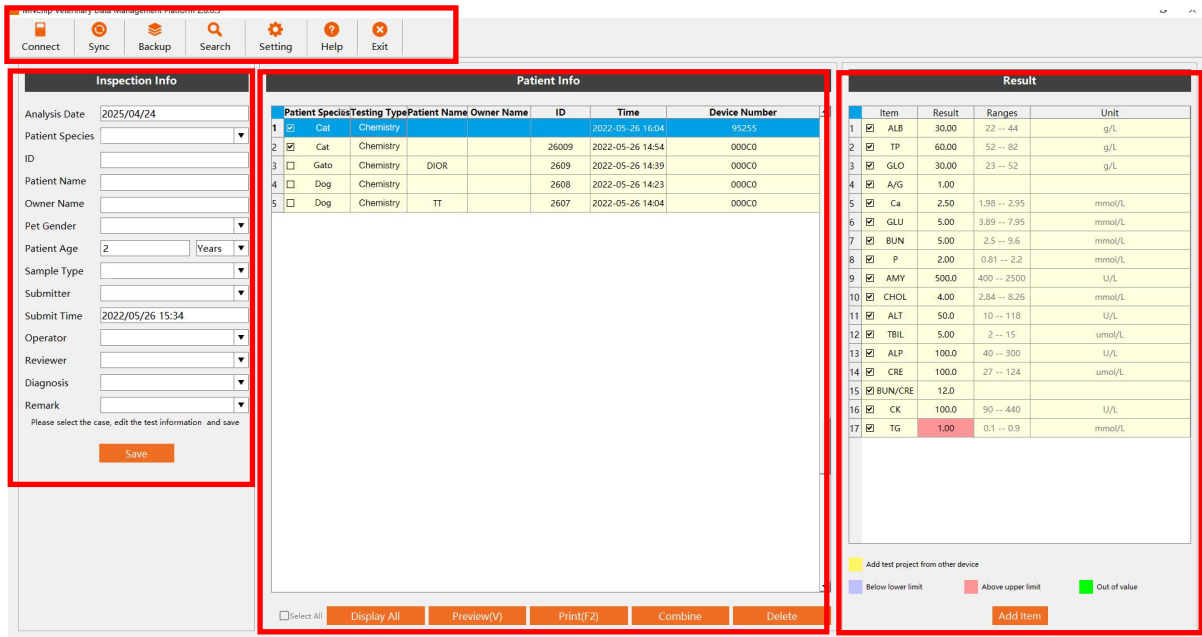

### 8.4.1 Inspection Info

Displays the patient information for the selected record. You can edit this information and click ‘Save’ to save the modified test details .

#### 1. Change inspection Information

Select a patient and update the basic information in the inspection area. Click ‘Save’ to finalize your changes .

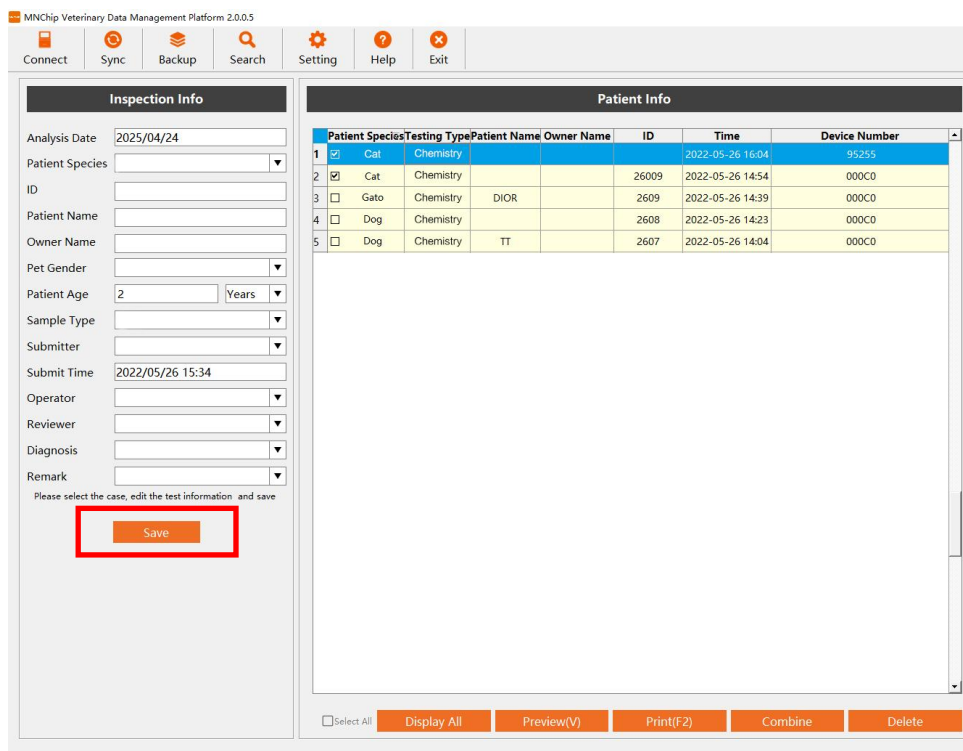

## 2. Display All

The ‘**Analysis Date**’ section on the home screen typically shows data for the selected date only. To view all test results, use the ‘**Display All**’ function.

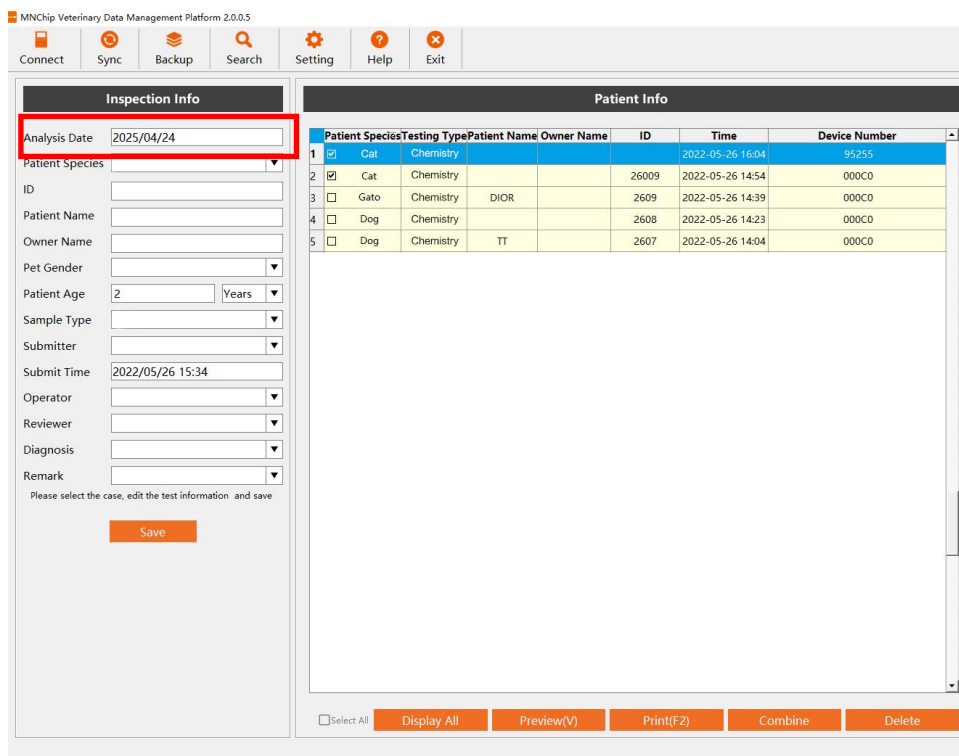

## 3. Combine

When a patient has been tested with different discs, you can combine the test reports into one using the merge function. First, select the reports to merge, then click the ‘**Combine**’ function. The system will generate a new report. For any duplicate test items in the combined results, the average value will be calculated, while unique items will be displayed separately.

	Patient Species	Testing Type	Patient Name	Owner Name	ID	Time	Device Number
1	<input checked="" type="checkbox"/> Cat	Chemistry				2022-05-26 16:04	95255
2	<input checked="" type="checkbox"/> Cat	Chemistry			26009	2022-05-26 14:54	000C0
3	<input type="checkbox"/> Gato	Chemistry	DIOR		2609	2022-05-26 14:39	000C0

## 4. Delete:

Select a result and click the ‘Delete’ function to remove it.

*Note: If you accidentally delete data, you can recover it by resynchronizing the data from the analyzer.*

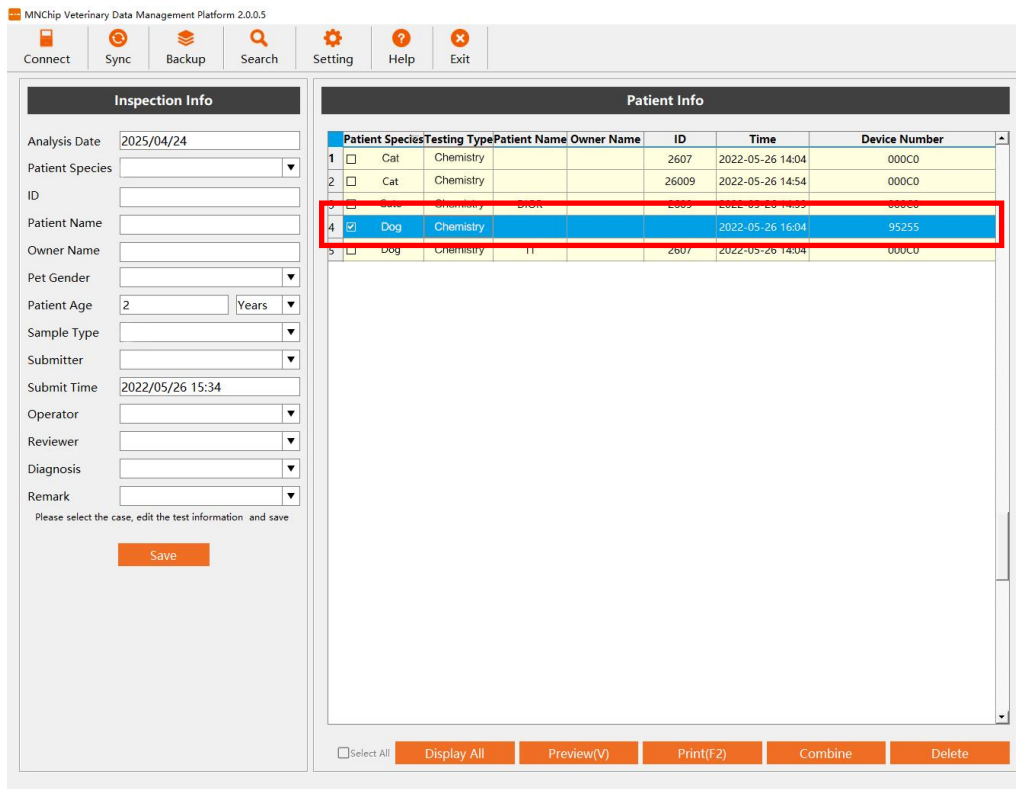

5. Add Item:

Select a test result and click ‘**Add Item**’ to create a new line. Double-click the blank space to add the required content.

*Note: The item you want to add must be different from existing items.*

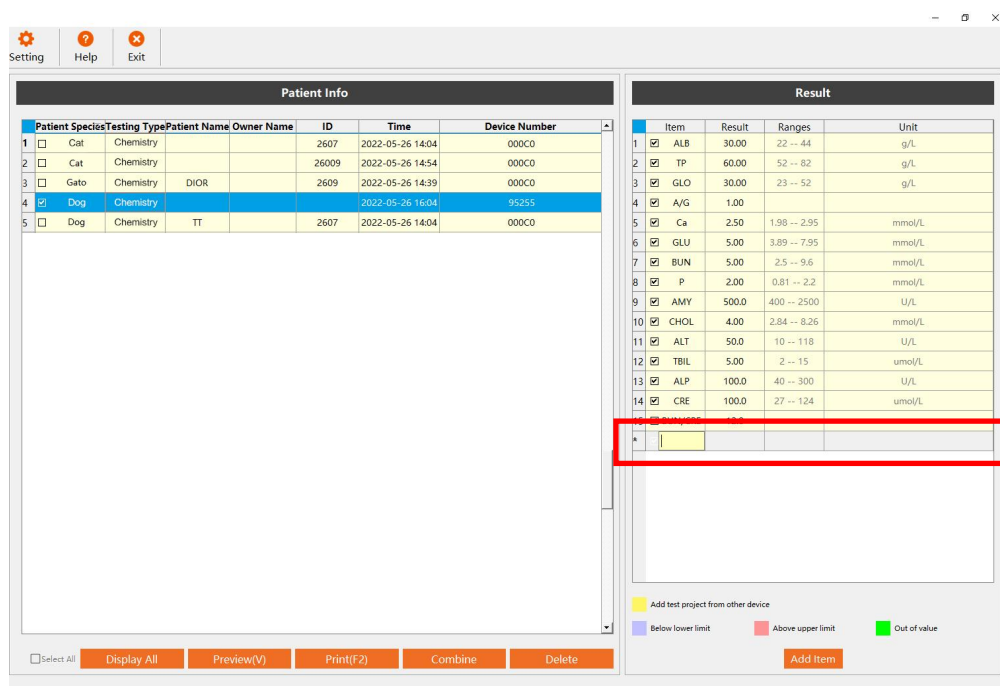

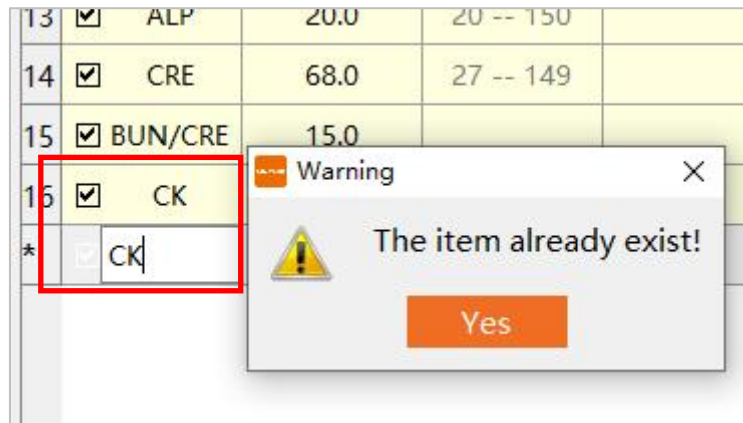

### 8.4.2 Patient Info

The test record matching the query is displayed, and the test record of the day is displayed by default.

- Click ‘Select All’: select all test records .
- Click ‘Display All’: display all test records .
- Click ‘Preview’: Preview all selected test record reports, or click ‘Quick Export ’ to export PDF.
- Click ‘Print’: print the selected test report, select the printer and set the print, then click ‘OK ’ to print. Click ‘Close ’ to modify the report form or cancel printing.
- Click ‘Combine’: Merge selected test records and generate new test records .
- Click ‘Delete’: cancel the selected test records .

### 8.4.3 Result

The patient test results for the selected record are displayed.

- Modify Test Results: Operators can modify specific test results by double-clicking on the test value.
- Add Test Items: Use this option to add additional test items .

## 8.5 Setting

Click the ‘ **Setting** ’button on the top menu bar of the management platform to access the settings interface.

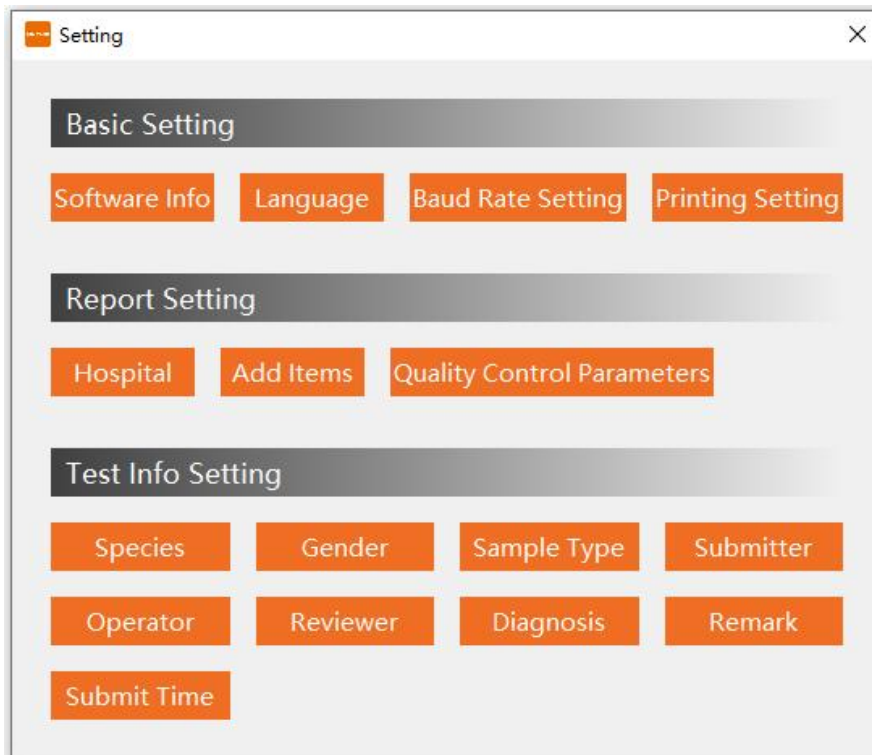

### 8.5.1 Basic Setting

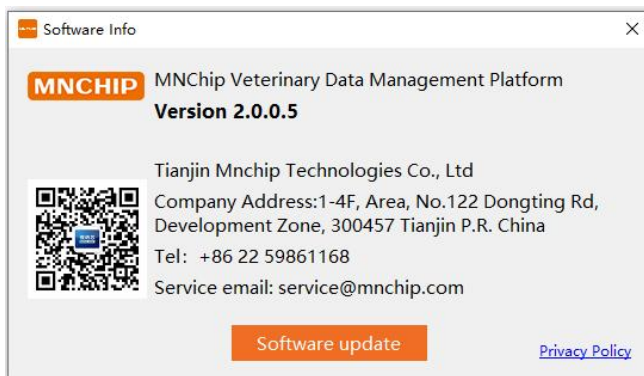

a. **Software Info:** Displays software information. Click ‘Software update ’ to upgrade.

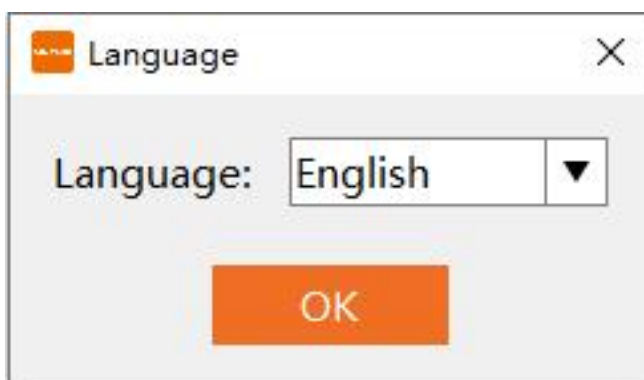

b. **Language:** Select your preferred language.

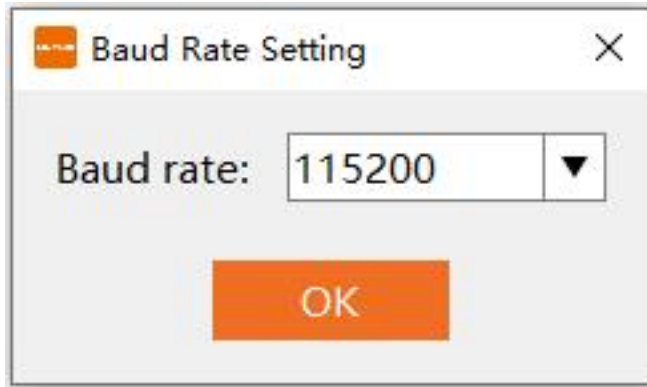

c. **Set Baud Rate:** Configure the baud rate for data transmission under ‘Local login’ .



d. **Printing Setting:**

- **Prompt Select:** Choose between ‘Chart’ and ‘Arrow’.
- **Paper Select:**
  - A5 vertical Print (default): Insert A5 paper (21 cm wide, 14.8 cm high) in the printer to print a report sheet.
  - A5 longitudinal print: Insert A5 paper (14.8 cm wide, 21 cm high) in the printer to print a report sheet.
  - A4 Print: Insert A4 paper in the printer to print the report sheet.
  - A4 clinical significance print: Prints with clinical significance of the test report; default choice is A4 paper.

### 8.5.2 Report Settings

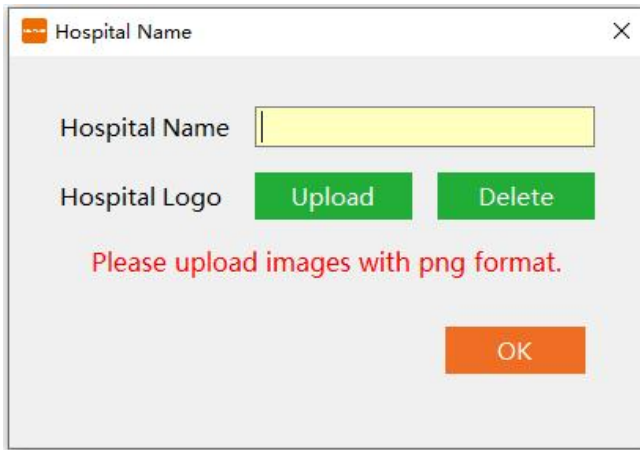

a. **Hospital name/Logo:** input the hospital name and logo.

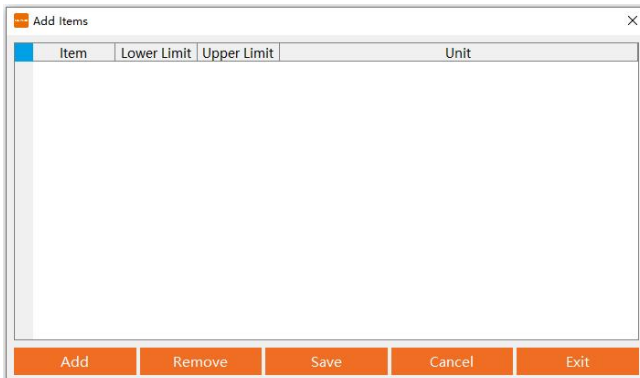

b. **Add Items:** use this function to combine the test items from other devices into one report. After making changes, click 'Save' and then 'Exit'.

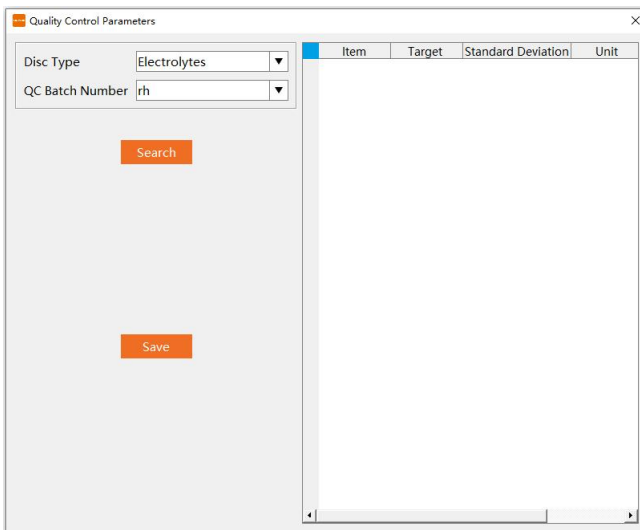

c. **Quality Control Parameters:** Use this function to update the quality control lot number, expiry date, and target value. After making changes, click 'Save' and then 'Exit'.

### 8.5.3 Test Info Setting

**Modify Test Info:** In the main interface, modify the 'Test Info'. Hospitals can preset each item in the '**Test Info Settings**' as needed, and these settings will be displayed in the report form.

Species

Species
3 Dog
4 Elephant
5 Goat
6 Horse
7 Monkey
8 Mouse
9 Ox
10 Pig
11 Rabbit
12 Sheep

Add Remove Save Cancel Exit

Gender

Gender
1 Male
2 Female
3 Neuter
4 中性

Add Remove Save Cancel Exit

Sample Type

Sample Type
1 Serum
2 Plasma
3 Whole Blood
4 粪便

Add Remove Save Cancel Exit

Submitter

Name

Add Remove Save Cancel Exit

*Note: The 'Inspection Note' highlights abnormal samples (hemolysis, lipemia, jaundice) by default. Hospitals can edit this note as needed. For abnormal samples, the report sheet background is red; for normal samples, it is yellow.*

Submitter	<input type="text"/>	10	<input type="checkbox"/>	Cat				20250211012	2025-02-11 21:50
Submit Time	2024/02/27 14:55	11	<input type="checkbox"/>	Cat		lucky		20250211009	2025-02-11 14:00
Operator	<input type="text"/>	12	<input type="checkbox"/>	Cat					2025-02-10 10:42
Reviewer	<input type="text"/>	13	<input type="checkbox"/>	Cat		MINN	Red		2025-02-09 19:50
Diagnosis	<input type="text"/>	14	<input type="checkbox"/>	Dog				20250209012	2025-02-09 17:21
Remark	<input type="text"/>	15	<input type="checkbox"/>	Cat					2025-02-09 17:09
Please select the case, edit the test information and save		16	<input type="checkbox"/>	Dog					2025-02-09 19:50
<input type="button" value="Save"/>		17	<input type="checkbox"/>	Dog			Yellow		2025-02-09 17:21
		18	<input type="checkbox"/>	Cat					2025-02-09 09:51
		19	<input type="checkbox"/>						2024-05-07 11:05

### 8.6 Switching Data Transfer Methods

Click 'Exit': close the management platform software. Click 'Switch', the 'Login'

screen will pop-up, follow the same steps as **8.3 Login**.

*Note: This function will only work under ‘CloudLogin’. The computer must be connected to the internet.*



### 8.7 Acquisition, Backup, and Querying of Patient Data

Under normal circumstances, the analyzer's test results can transmit patient data to the management platform via ‘Cloud login’ and ‘Local login’. If the results are not transmitted to the management platform, manual transfer methods can also be attempted to resolve the issue.

1. Click ‘Sync’ to search for all currently connected devices. If the connection is successful, the connected device will appear on the right side of the main menu.

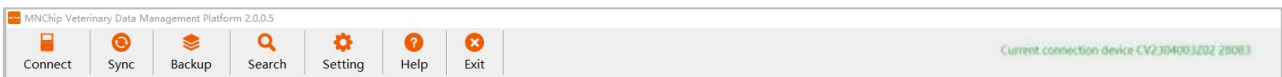
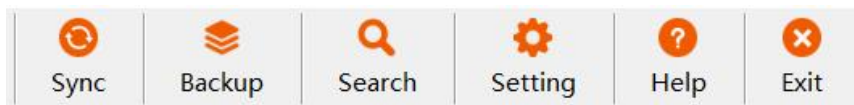

*Note: When you open the management platform software, results from the day are automatically synchronized by default. If data synchronization fails, locate the report in the chemistry analyzer's Results Query and click 'Upload'*

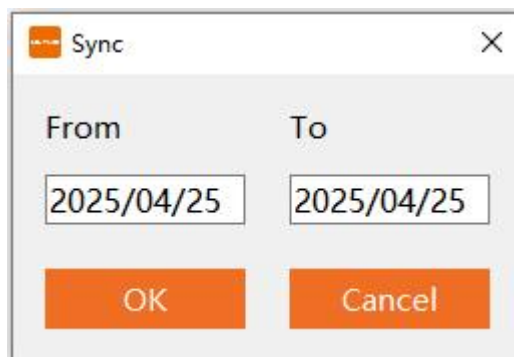

2. Click ‘Backup’ to back up or restore your data.

- ‘Data Backup’: Back up data from the current management platform software to the specified location.

- **‘Data Recovery’**: Select the **‘.mdb’** file you want to recover.



3. Click **‘ Search ’** to find the test records that meet the specified screening conditions . Enter any one or any combinations of test date range, name, medical record number, gender, age, device ID, project name and result range to screen report sheets .

## 8.8 Report Printing

1. Report preview: Select one patient result, the print preview will be shown.

Biochemical Inspection Report				
Name: Wang	Sex: Male	Age: 51 years	ID: ID3	Bed No.:
Sample Type: Serum Sample	Department:		Patient Area:	
Clinical Diagnosis:				
LOT: 34173-6-0148-0227-20-241152-14090				
Item	Result	Indicator	Ranges	Unit
ALT	27		7-40	U/L
AST	21		13-35	U/L
TBIL	16.90		3.4-20	umol/L
DBIL	≤2		0-6	umol/L
IBIL	16.10		0-17.1	umol/L
TP	84.00		65-85	g/L
ALB	52.60		40-55	g/L
GLO	31.40		20-40	g/L
A/G	1.70/1		1.2-2.4/1	
UREA	5.34		2.9-8.2	mmol/L
CRE	56		45-84	umol/L
UA	341		155-357	umol/L
GLU	6.76	↑	3.9-6.1	mmol/L
TG	0.77		0-1.7	mmol/L
CHOL	5.26	↑	0-5.2	mmol/L
HDL-C	1.76	↑	1.29-1.55	mmol/L
LDL-C	3.15	↑	0-3.12	mmol/L
Submit Datetime:	2025-02-18 10:15	Analysis Datetime:	2025-02-18 10:25	Print Datetime:
Submitter:		Operator:		2025-04-18 17:37
Reviewer:				
Remark: <i>The result is only responsible for this sample</i>				

2. Report print: Reports can be printed using the printer installed on a Windows PC. Select the report to be printed, click **‘Print (F2)’**.

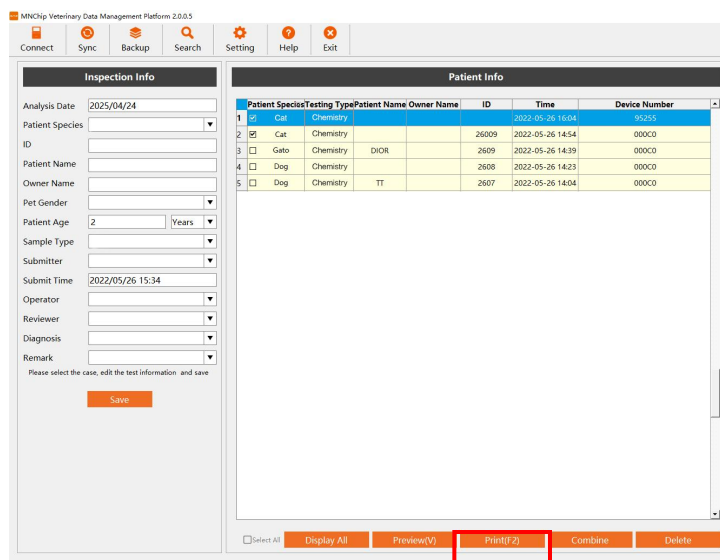

Select the corresponding printer to print.

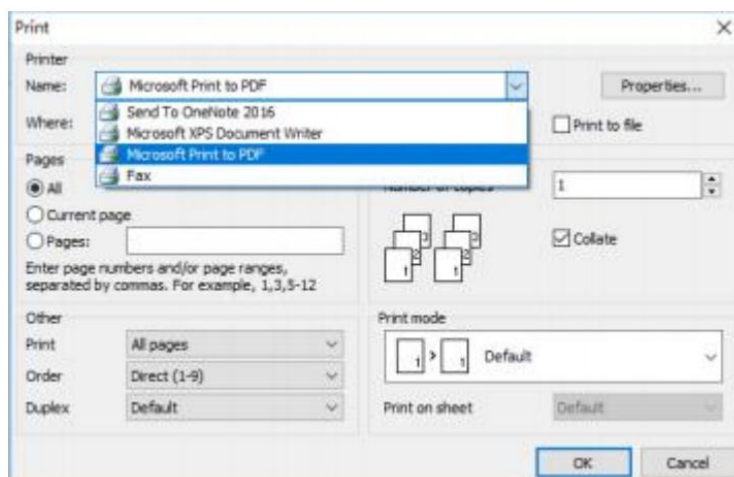

*Note: If the PC is not connected to the designated printer, please install the printer first. You can design the reporter layout using the printer's report setup function.*

## 8.9 Troubleshooting

If the test results cannot be synchronized with MMDMP, try the following solutions:

### 1. Update the Analyzer Software Version:

- Turn on the analyzer and go to 'Setting' — 'Network' to connect to WiFi.
- Once connected to the Internet, return to 'Setting' — 'Chemistry analyzer' and update the software to the latest version.

### 2. Check Connection Based on Login Type:

- For **local login**, ensure that the data cable is connected properly, then reboot both the Analyzer and management platform software.
- For **cloud login**, verify that both the Analyzer and PC with the software are connected to the Internet.

### 3. Reinstall MMDMP Software:

- Locate the uninstallation tool in your installation documentation and run unins000.exe to uninstall MMDMP, then click Yes to confirm.
- After uninstalling, reinstall the software as described in **section 8.1**.

